

P52

Discover the pleasure of performance



- Unique parallel movement
- Runs on low oil flow, 60-65% less than a traditional crane
- Easy to control, the crane tip moves in a straight line

Crane P52

FTG Källefäll crane P52 provides a total reach up to 5.2 m and a 450 kg lifting capacity at the max reach.

Unique parallel movement that maintains the same lifting moment throughout the range. Only one cylinder is active for this movement.

Runs on low oil flow, 60–65% less than a traditional crane. This makes it possible to reduce the number of revolutions and improve fuel consumption and the environment.

Crane P52 comes standard with 3 ton rotator, FB160 grapple, rotator link without pending brake, mechanical control, 4 cylinder slewing motor. The forest crane has a

lifting moment of 28 kNm (gross) and a slewing torque of 8.5 kNm. There are numerous valve packages and accessories to choose from. Crane designed for versatile work applications:

- Forest trailers
- Chippers
- Log splitters
- Attachment to the tractor

P52 combined with FTG Källefäll forest trailers offers high reliability and efficiency. Demand for maintenance is quite low for high-quality components and tested designs

Suitable trailers:

- [FB70](#)

Technical characteristics Crane (standard equipment)

<i>Parameter</i>	<i>P52</i>	<i>Parameter</i>	<i>P52</i>
Reach, m	5,2	Slewing angle, °	360
Linkage system	Yes	Total weight, kg	520
Telescope extension, m	–	Oil flow, l/min	20–25
Lifting moment (gross), kNm	28	Rotator, type	3 t
Lifting moment (Net), kNm	23	Rotator link, type	Without pending brake
Lifting capacity at max reach, kg	450	Grapple, type	FB160
Lifting capacity at 4m, kg	550	Valve block, type	Mechanical (2–Lev. / 3–Coord.)
Slew torque, kNm	8,5	Working pressure, bar	185

Technical drawings

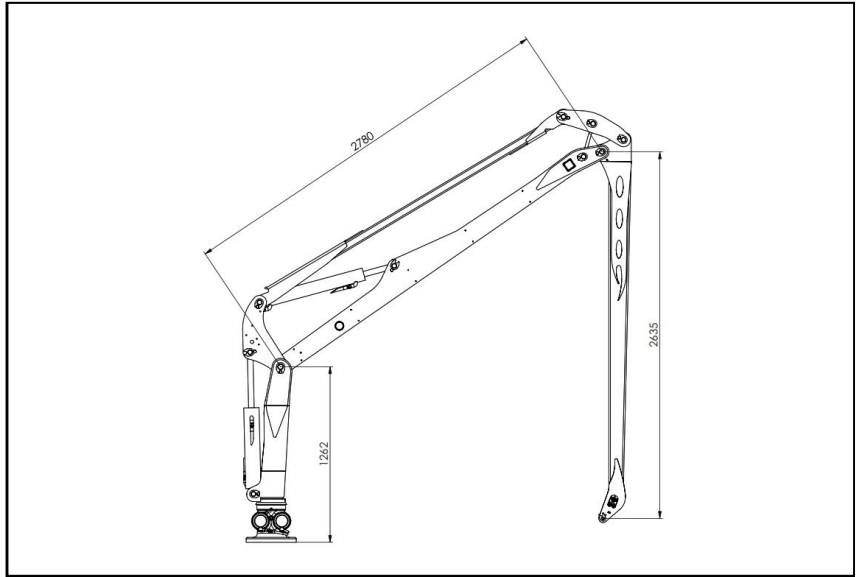
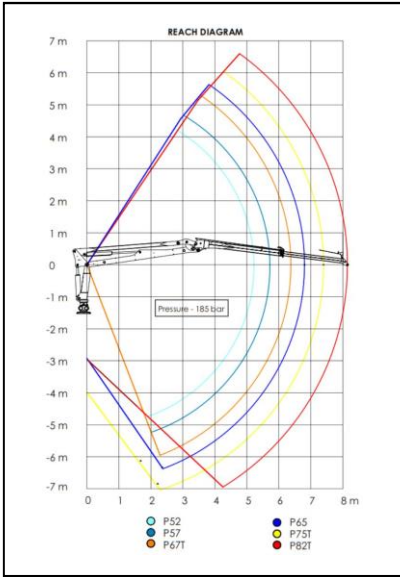

P52 accessories

Control system

Mechanical
FRV60/8-E, 2 x EL.
On/Off



Mechanical 2-Lever,
Lightweight, 4 x EL.
On/Off



Prehydraulic
FRV60EO with
Joysticks



Full electric with
with ERGO-
DigiStick® Joysticks



Radio control
Scanreco®



Winch

1410 KPL with
remote control



3-P attachment

A-frame type,
CAT. I



Independent hydr.
system for 3-P
attachment



Block valve for
telescopic
support legs



Grapple

Grapple FB120
(0.12 m²)



Brush grapple
FB160S (0.16 m²)



Round bale
attachment for
grapple FB160



Add-on bucket for
grapple



Bucket-grapple
KG180 (0.11 m³)



Other accessories

Chainsaw holder



LED work light on
crane boom



LED work light on
crane pillar



Supply pressure
monometer



Connection of hydr.
hoses on pillar



Shut-off valve for
lifting cylinder

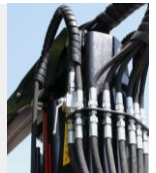

Valve block
cover



FTG BALTIC UAB

Dūmų st. 3 K20
LT-11119 Vilnius, Lithuania
+370 5 246 23 18
sales.vilnius@ftgforest.com

By combining our Swedish heritage with constant innovation based on the needs of customers, we design forest trailers and cranes that impress by their consistently pleasant performance.

FTG Källefäll forest trailers can pass through challenging terrains and are robustly built to withstand tough conditions in the forest. Trailers' capacity varies from 2,5 to 12 tones. Our trailers can be supplemented with telescopic cranes, ranging from 4,2 to 9,4 meters reach. Källefäll cranes are strong, fast, and easy to operate. We also offer a wide range of timber grapples and other accessories to meet different needs.

For more information: www.ftgforest.com