

Mv94T

Discover the pleasure of performance



- Broad range of control and accessory options
- LED work light attachment for better visibility and safety
- Strong and lightweight grapples

Crane Mv94T – a powerful crane for the most demanding needs

FTG Källefäll crane Mv94T has a total reach of 9,4 m, a 500kg lifting capacity at full reach, 1 250kg at 4 m.

The Mv94T has a number of improved features: longer reach, higher lifting torque, greater slew torque and better movement pattern. The crane has a newly developed dual telescope boom with protected hose routing.

As standard, the crane is equipped with grapple FB260, 6t flange rotator with braked link and mechanical valve block CRV80/8A.

There are numerous valve packages and accessories to choose from. Crane designed for versatile work applications:

- Forest trailers
- Chippers
- Log splitters
- Attachment to the tractor

Mv94T combined with FTG Källefäll forest trailers offers high reliability and efficiency. Demand for maintenance is quite low for high-quality components and tested designs

Suitable trailer:

- [FB120D](#)

Technical characteristics Crane (standard equipment)

<i>Parameter</i>	<i>Mv94T</i>	<i>Parameter</i>	<i>Mv94T</i>
Reach, m	9,4	Slewing angle, °	360
Linkage system	Yes	Total weight, kg	1 400
Telescope extension, m	3,38	Oil flow, l/min	70-90
Lifting moment (gross), kNm	81	Rotator, type	6 t, flange
Lifting moment (Net), kNm	47	Rotator link, type	With pending brake
Lifting capacity at max reach, kg	500	Grapple, type	FB260
Lifting capacity at 4m, kg	1 250	Valve block, type	Mechanical (2-Lev. / 3-Coord.)
Slew torque, kNm	21	Working pressure, bar	185

Technical drawings

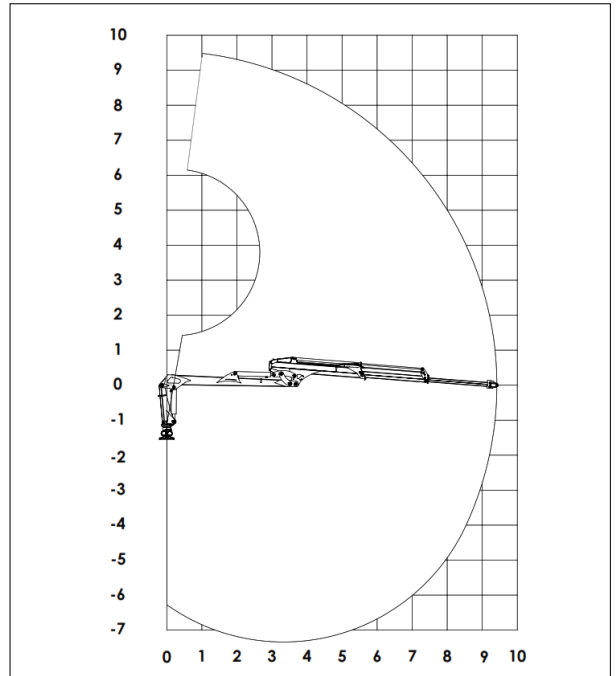
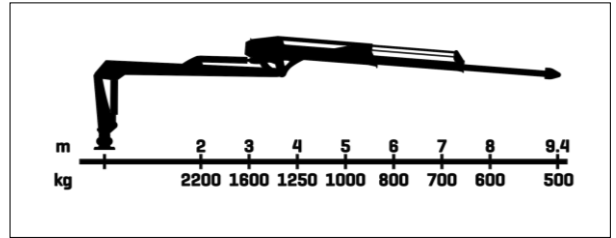
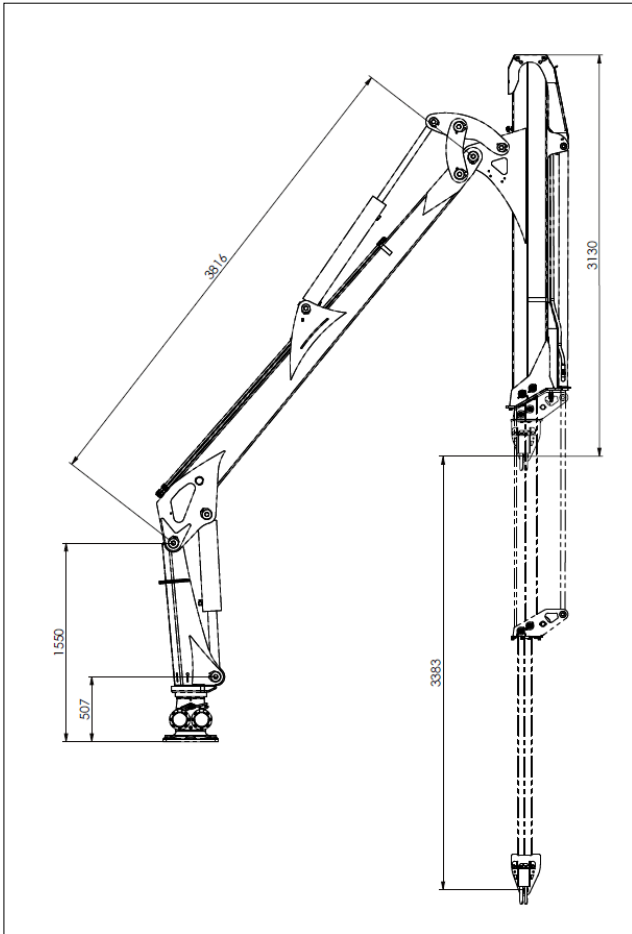

Mv94T accessories

Valve block

Mechanical
Hydrocontrol 2/8
On/Off (80l/min)

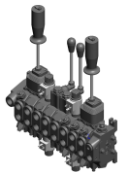

Full electric with
with Joysticks



Radio control
Scanreco®



Winch

1410 KPL with
radio control



3-Point attachment

A-frame type,
CAT. III



Independent hydr. system for 3-P attachment

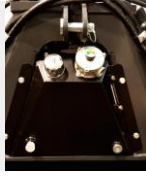

Block valve for support legs



Grapple

Grapple FB210 (0.21 m²)



Brush grapple FB210S (0.21 m²)



Brush grapple FB190S (0.19 m²)



Grapple FB190WF (0.19 m²)



Clamshell bucket KG180 (0.11 m³)



Add-on bucket for grapples



Other accessories

Protection plate for lifting cylinder



LED work light on crane boom



LED work light on crane pillar



Chainsaw holder



Valve block cover



Shut-off valve for lifting cylinder



Supply pressure monometer



FTG BALTIC UAB

Dūmų st. 3K20
LT-11119 Vilnius, Lithuania
[+370 5 246 23 18](tel:+37052462318)
sales.vilnius@ftgforest.com

For more information: www.ftgforest.com

By combining our Swedish heritage with constant innovation based on the needs of customers, we design forest trailers and cranes that impress by their consistently pleasant performance.

FTG Källefäll forest trailers can pass through challenging terrains and are robustly built to withstand tough conditions in the forest. Trailers' capacity varies from 4 to 12 tones. Our trailers can be supplemented with telescopic cranes, ranging from 4,2 to 9,4 meters reach. Källefäll cranes are strong, fast, and easy to operate. We also offer a wide range of timber grapples and other accessories to meet different needs.