

F O R E S T R Y   E Q U I P M E N T

**USER MANUAL  
&  
SPARE PARTS CATALOGUE  
TRAILER & CRANE**



---

## CONTENT

-----INSTRUCTION MANUALS-----	1
TIMBER TRAILER	3
TIMBER CRANE	23
CONTROL SYSTEM	45
ON-BOARD HYDRAULIC SYSTEM	54
TRAILER	60

---

## IMPORTANT!

Thank you for choosing FTG product! We recommend you to read this user manual thoroughly. Follow the advices and instructions carefully to provide the best possible conditions for safe and reliable use.

**Factory warranty to be voided if instructions will be omitted.**



# USER MANUAL

---

F O R E S T R Y   E Q U I P M E N T

## TIMBER TRAILER

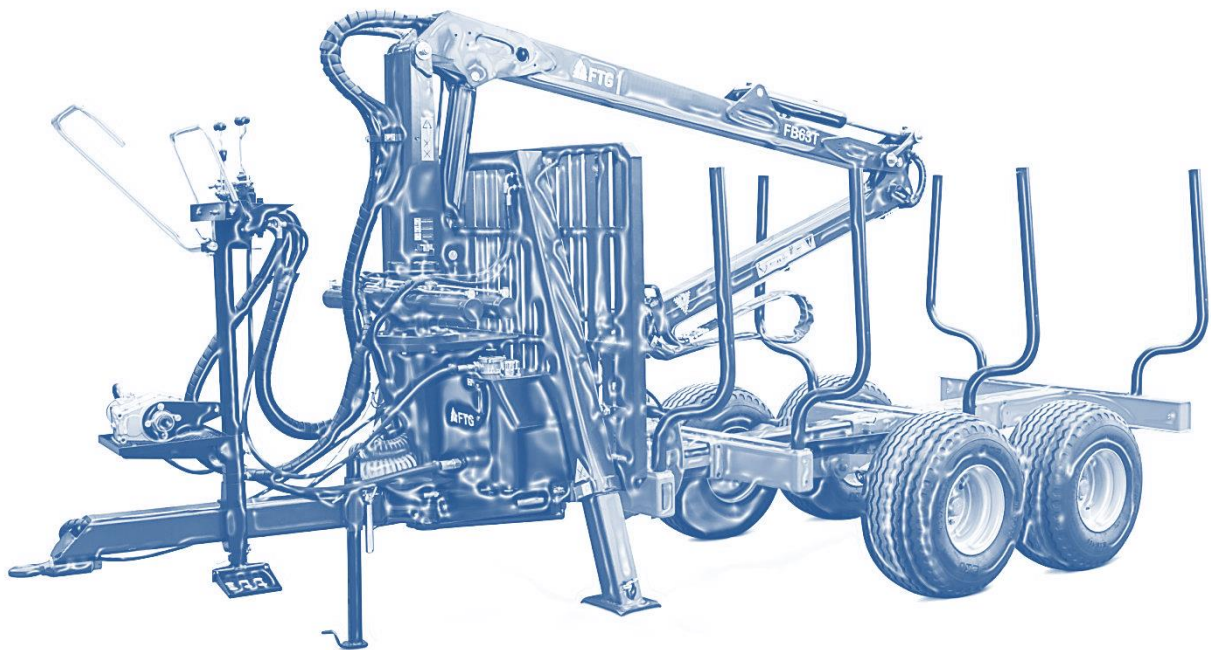

---

*A great day in a forest!*

---

## Contents

1	INTRODUCTION .....	3
2	BASIC SAFETY INSTRUCTIONS.....	4
2.1	Description of warning symbols.....	4
2.2	General safety regulations .....	4
2.3	Instructions for safe use.....	4
2.4	Explanation of the labels on equipment.....	5
3	TECHNICAL DESCRIPTION.....	7
3.1	Single beam trailer frame main parts.....	7
3.2	Double beam trailer frame main parts.....	8
3.3	Tightening torques.....	9
3.4	Air pressure in the tires .....	9
4	NEED TO KNOW BEFORE DRIVING .....	10
4.1	Coupling the trailer .....	10
4.2	Driving the trailer.....	11
4.3	Decoupling and parking the trailer .....	12
4.4	Operating instructions.....	12
5	MAINTENANCE AND SERVICE.....	15
6	AUXILIARY WHEEL DRIVE SYSTEM .....	17
6.1	General.....	17
6.2	Automatic wheel drive control system .....	17
6.3	Connecting wheel drive control system .....	18
6.4	Operating instructions.....	18

## 1 INTRODUCTION

Congratulations on choosing FTG product. We hope you will be satisfied with it. We recommend you, read through this instruction manual to familiarize yourself with all the product parts. This user manual contains the information needed to look after your forestry equipment. Take time to read it through thoroughly.

The user's manual describes the construction of the equipment, it's maintenance and how it should be handled. Follow the advice and instructions carefully. This will provide the best possible conditions for safe and reliable use and for the factory warranty to be valid. If major repairs are needed, never hesitate to contact your service workshop, which will have the resources and knowledge necessary to help you with any difficulties.

Inspect your product on delivery. If it has been damaged during delivery or transport, or if any parts are missing, contact your dealer.

We reserve the right to make modifications to the equipment, data and the user's instructions without prior notice.

**Good luck with your new FTG equipment!**



**Factory warranty – follow the user instructions!**

## 2 BASIC SAFETY INSTRUCTIONS

### 2.1 Description of warning symbols

The terms Warning and Note are used regularly in this user manual to alert reader about important information. These terms are used as follows:



**A very important item of safety information. It indicates risk of serious or fatal injury or serious damage to equipment.**

**NOTE:** Indicate tips and suggestions for making operations easier and/or faster. This information is not safety-related.

### 2.2 General safety regulations



**Carefully read through the user manual and trailer's technical data before using the timber trailer.**

The employer must ensure that:

- The user has read these instructions before using the trailer with crane .
- These instructions are available at the work site.
- The local regulations and government requirements, regarding the operations, are known and followed.
- User must take care, that nobody is within the safety zone (20 m).

Operating a crane requires a high level expertise to perform operations, as well as knowledge about the machine you are using. If you follow the indicated safety regulations and the crane's technical data, neither the user's nor the machine's safety are put at risk.

### 2.3 Instructions for safe use



**Unauthorized persons are forbidden to enter the machine's risk zone of 20 m.**



**Never leave the tractor cab unless the tractor's parking brake is applied and the engine is switched off.**



**Never use the trailer to transport people or animals.**

- Test drive the machine before starting to use.
- Ensure that the machine is standing on secure ground and underlying surface is stable enough to support maximum possible load.
- The trailer must be fitted with correct lightning and a number plate (rear lights, stop lights, blinkers), if it is to be driven on the public roads during hours of darkness.
- Country's laws and regulations must always be complied with.
- The user must ensure he has full visibility over the work area.
- Do not overload the trailer.
- The support legs must be used to protect the trailer from overturn. Support legs must be fully raised before moving the trailer.
- Ensure that tractor's parking brake is applied when trailer is under loading.

## 2.4 Explanation of the labels on equipment



### **Warning sign and user manual label**

User must read entire user manual carefully before starting to use the trailer.



### **Label for use of safety equipment**

These labels inform the user to employ appropriate safety equipment.



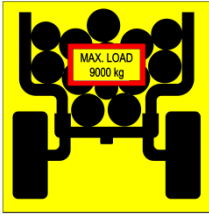

### Max. load

It is strictly prohibited to load the trailer more than specified on a label or ID plate.



### Max. load on towing eyelet

It is strictly prohibited to load eyelet more than specified on label or ID plate.



### Warning! Risk of damage or injury.

Ensure that the area around the support legs is free and there are no people or things that can be injured or damaged when support legs are folding out.





### Warning! Rotating parts.

Indicates a risk of rotating parts. Be sure never to touch any of rotating components like PTO driven hydraulic pump, wheel drive or similar.



### Warning! Risk of clamping injuries

Indicates a risk of clamping injuries during work or maintenance.

TRADEMARK / MFGD WARENZEICHEN / BAUJAHR	/	/
TRAILER TYPE / SN# RÜCKEWAGEN TYP / SN#	/	/
VIN #		
MAX. PERMITTED TOTAL WEIGHT, kg ZUL. GESAMTGEWICHT, kg		
EMPTY WEIGHT, kg LEERGEWICHT, kg		
LOAD CAPACITY, kg NUTZLAST, kg		
MAX. AXLE LOAD, kg ZUL. ACHSLAST, kg	A1	A2
MAX. LOAD ON TOWING EYELET, kg ZUL. STÖTZLAST, kg		
MAX. SPEED, km/h ZUL. GESCHWINDIGKEIT, km/h		
 FTG BALTIC UAB, DŪMŪ ST. 3, LT11119, VILNIUS, LITHUANIA WWW.FTGBALTIC.LT		

### Manufacturer ID plate

Equipment supplied with an ID plate. It states the serial number, year or production, model name, max. working pressure and other information (if applicable).

### 3 TECHNICAL DESCRIPTION

#### 3.1 Single beam trailer frame main parts

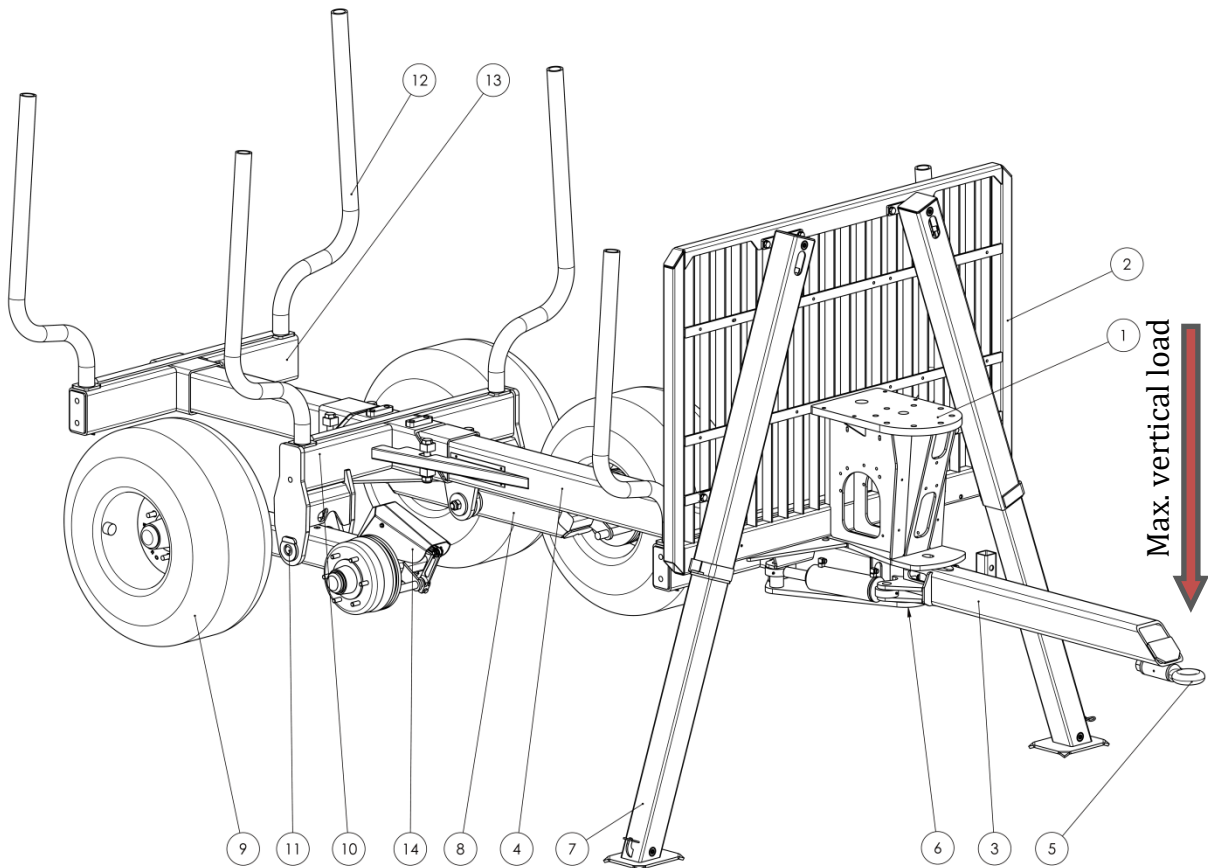

- |                          |                  |
|--------------------------|------------------|
| 1. Base plate            | 8. Bogie         |
| 2. Gate                  | 9. Wheel         |
| 3. Drawbar               | 10. Chassis      |
| 4. Central beam          | 11. Bogie axle   |
| 5. Towing eyelet         | 12. Stake        |
| 6. Frame steering axle   | 13. Bunk         |
| 7. Hydraulic support leg | 14. Brake system |

### 3.2 Double beam trailer frame main parts

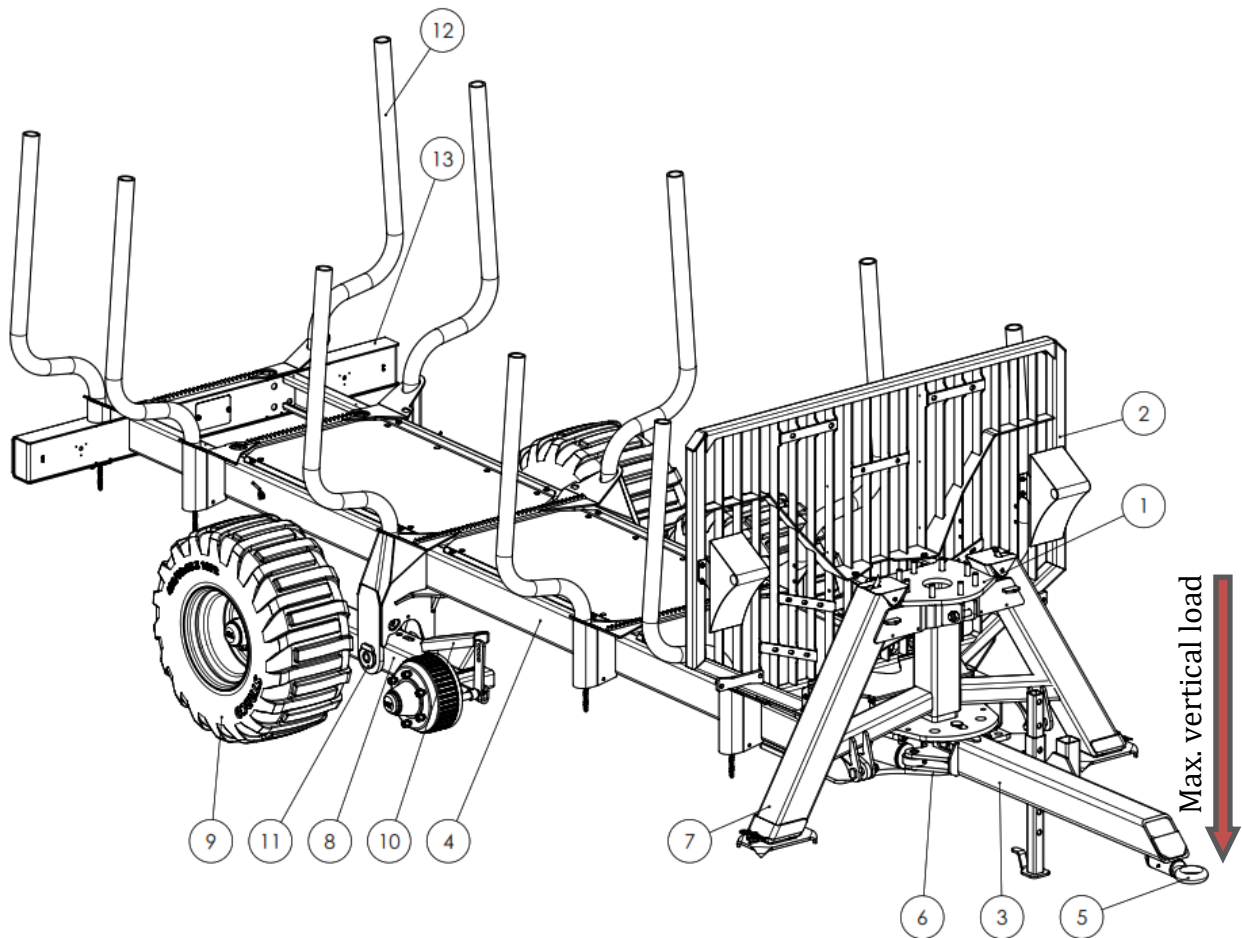

- |                          |                  |
|--------------------------|------------------|
| 1. Base plate            | 8. Bogie         |
| 2. Gate                  | 9. Wheel         |
| 3. Drawbar               | 10. Brake system |
| 4. Trailer frame         | 11. Bogie axle   |
| 5. Towing eyelet         | 12. Stake        |
| 6. Frame steering axle   | 13. Bunk         |
| 7. Hydraulic support leg |                  |



**Max. vertical load on towing eyelet depends on your trailer model and towing eyelet type. User has to ensure that permitted max. vertical load on towing eyelet will never exceed the intended amount.**

### 3.3 Tightening torques

All bolts and nuts should be inspected and tightened after each 10 hours of operation.  
Allowable torque range max.  $\pm 5\%$ .

Thread	Class 8.8	Class 10.9	Class 12.9
<b>M8</b>	23 Nm	32 Nm	39 Nm
<b>M10</b>	46 Nm	64 Nm	77 Nm
<b>M12</b>	80 Nm	112 Nm	135 Nm
<b>M14</b>	125 Nm	180Nm	210 Nm
<b>M16</b>	190 Nm	270 Nm	330 Nm
<b>M18</b>	270 Nm	370 Nm	460 Nm
<b>M20</b>	380 Nm	530 Nm	640 Nm
<b>M24</b>	665 Nm	935 Nm	1100Nm
<b>M30</b>	1300 Nm	1800 Nm	2200 Nm
<b>M18X1.5(wheel)</b>	-	460 Nm	-

### 3.4 Air pressure in the tires

Air pressure should be inspected after each 20 hours of operation or at least once per week. Incorrect pressure can cause uneven tire wear or tire blow-out.

Tire dimension	Max. air pressure (Bar)	Max. load (kg) 30km/h
11.5/80x15.3, 10pr AW-909 TL	4,6	2300
12.5/80x15.3 14pr. AW-702 TL	4,3	2650
400/60x15.5, 14pr ST-156 TL	4,9	3250
400/60x15.5, 14pr TR-882 TL	4,9	3250
400/60x15.5, 14pr TR-882 TL (RR)	4,9	3250
500/50x17 18PR FL648	4,0	4620
500/50x17 TT FL-648 (RR)	4,0	4620
550/45-22.5 20PR BKT FL 648	4,0	5300
600/50x22,5 TT 16PR BKT FL-648	4,0	5150

## 4 NEED TO KNOW BEFORE DRIVING

### 4.1 Coupling the trailer

During loading and transport on the public roads, follow the relevant traffic laws.

**NOTE:** When coupling and decoupling the trailer, be aware of the risk of crushing, catching, slipping, tipping, high-pressure hydraulic oil jets and hot oil. Ensure that the hydraulic pump and PTO shaft are disconnected.

- Check that the towing eyelet lock is undamaged and completely tightened.
- Connect the trailer's towing eyelet to the tractor's tow hook. Make sure the towing equipment locks correctly. Check that the bolted joints on the chassis and crossbeam are strong tightened against the central beam.
- Check the condition and air pressure of the tires.
- Check that the wheel nuts are tightened.

### Connecting the trailer steering (where applicable)

Connect both the hydraulic hoses for the trailer steering cylinders to one of the tractor's double-action hydraulic outlets. Check that the quick couplings are clean and capable of locking securely.

### Connecting the hydraulic brakes (where applicable)

- Connect the hydraulic brake hose to the tractor's brake valve or single-action hydraulic outlet.

**NOTE:** When the trailer's brake line is connected not to a brake valve, pressure can build up in brake system, due to internal leaking in the tractor's hydraulic system. Always make sure that the brakes are not applied before starting to drive.



#### Brakes pressures

Before connecting brake line, ensure correct pressure output from the tractor – otherwise there is a high risk to damage the seals in brake cylinders or have ineffective brakes. Optional pressure reducer valve may be used to ensure correct pressure.

Brake type	Pressure
Hydraulic brake (internal cylinder)	160 bar max.
Hydraulic brake (external cylinder)	120 bar max.
Hydro pneumatic brake	7.0-8.1 bar
Pneumatic brake	7.0-8.1 bar

### Connecting the pneumatic brakes (where applicable)

- Connect the pneumatic hoses to tractor's pneumatic brake outputs. Ensure correct connection – red coupling goes for constant pressure supply and yellow coupling goes for a service brake line.

**NOTE:** Make sure the seals of the coupling heads are in good condition. The seals must be clean and undamaged.

#### Pneumatic brakes max. pressure 8.1 bar.



With a trailer coupled, start move only when the pressure gauge in the tractor's cab indicates a pressure at least of 5.0 bar – otherwise the brakes may still remain locked.

### Travel lights

- Connect the trailer's tail lights connector to the tractor's power outlet (12v), before driving on the public roads.

## 4.2 Driving the trailer



#### Frame steering on slopes.

If the trailer's frame steering is used on slopes, there is a high risk of overturn.



#### The support legs must be fully raised before moving the trailer.

- Ensure that the load is secured.
- Unlock the trailer's steering lock.
- Start the tractor's hydraulic pump or PTO shaft.

- Carefully check the movements of trailer's steering. Jerkily movements are the sign that there is an air in the hydraulic system. Check that none of hoses is stretched or chafing to sharp edges.
- Check the movements of the support legs.
- Check if the tail lights work (rear lights, stop lights, blinkers).
- Check the brakes.

**Note:** when operating a new trailer for the first time, check all hoses and tubes connections after five hours of work and tighten them if necessary. Damp patches on the hose and tube connections are a sign that they are starting to leak.

### 4.3 Decoupling and parking the trailer



#### **Hot oil! Risk of burn injuries.**

Take care disconnecting hydraulic hoses. Oil can be very hot.

- Park the trailer on a flat, stable surface. Fix the parking leg in the right position or put the support under the drawbar. Apply trailer's parking brake or put the chocks by trailer's wheels to prevent it rolling away.
- Switch off the tractor's hydraulic pump and PTO shaft. Ensure that there is no remaining hydraulic pressure.
- Disconnect hydraulic and pneumatic hoses.

**NOTE:** First disconnect hydraulic pressure hoses, after – return lines. Afterwards disconnect pneumatic brake hoses. Firstly disconnect red coupling, then yellow coupling. Finally disconnect the tail lights connector. Make sure that protective plugs are installed on hydraulic and pneumatic hoses. Don't leave hoses and electrical cables hanging to the ground. Use special hose holders on the trailer – this eliminates the risk of damage.

- Now it is time to disconnect the trailer's towing eyelet from the tractor's tow hook.

### 4.4 Operating instructions



**If accidents or damages occur during operation, the work must be stopped immediately. Repair all the damages before using the trailer again.**

## **Optimum weight distribution**

Weight distribution is exceptionally important for smooth operation. The optimum weight distribution is the one, when timber's center of gravity is directly above the front bogie wheels.



## Driving through narrow passages

When driving through narrow passages, the trailer can be steered using frame steering. Remember, that there is a slight risk of overturn, so always use delicate lever movements.

## Loading and unloading

You must give particular attention to stability during loading/unloading. Stability can be increased by slewing the trailer drawbar to the opposite direction from that the crane is working in. It is highly recommended to use support legs each time during loading / unloading.

## Sideways slope

When driving on a sideways slope, the risk of overturn can be reduced by steering the trailer higher up than the tractor.

## Driving off-road

- Drive straight uphill or downhill in hilly country. Do not try to drive down slopes that are too steep to drive up.
- Remember – it is more difficult to control a big and heavy load than a smaller and lighter one – adapt the size of the load to the size of a tractor and the ground conditions.
- Bear in mind that when the trailer is loaded, it has a higher center of gravity than the tractor – this means higher risk of overturn.



**If the tractor overturns, hold tightly to the steering wheel and do not jump out. In this situation, you are the safest inside the cab.**

## Working in extreme conditions

Recommended environment working temperature for the crane is -25°C to +40°C. Remember – when working under extreme conditions, work with smaller loads than normal. Before working in cold conditions, always warm up the machine. Let the hydraulic oil to circulate freely for a couple of minutes. During hot conditions, take care about the temperature of hydraulic oil. Maximum temperature of oil can not exceed 80°C – otherwise the crane may stop work, due to potential damage to seals.

## 5 MAINTENANCE AND SERVICE

To maintain the trailer's excellent operating properties and ensure a long service life, the individual components should undergo regular maintenance. Carefully follow the instructions in this section.

- If you see any cracks or damages on crane's supporting parts, operation must be stopped immediately.
- Clean trailer with water before make service and repairs. Take care not to spray electrical components with high-pressure cleaning equipment.
- Worn bolts and screws can cause accident when crane is working.
- Lubricate trailer after cleaning.
- All services and repairs must be performed with the unloaded trailer.
- Be careful not to slip when climbing onto the trailer during the service and repair.
- When dismantling the trailer's parts, mark each part to facilitate re-assembly after repairs.
- Use only original spare parts.

Follow the service schedule below. Make sure that the axles are unloaded during lubrication – this ensures a good effect of the lubrication. Also clean the grease nipples before lubrication.

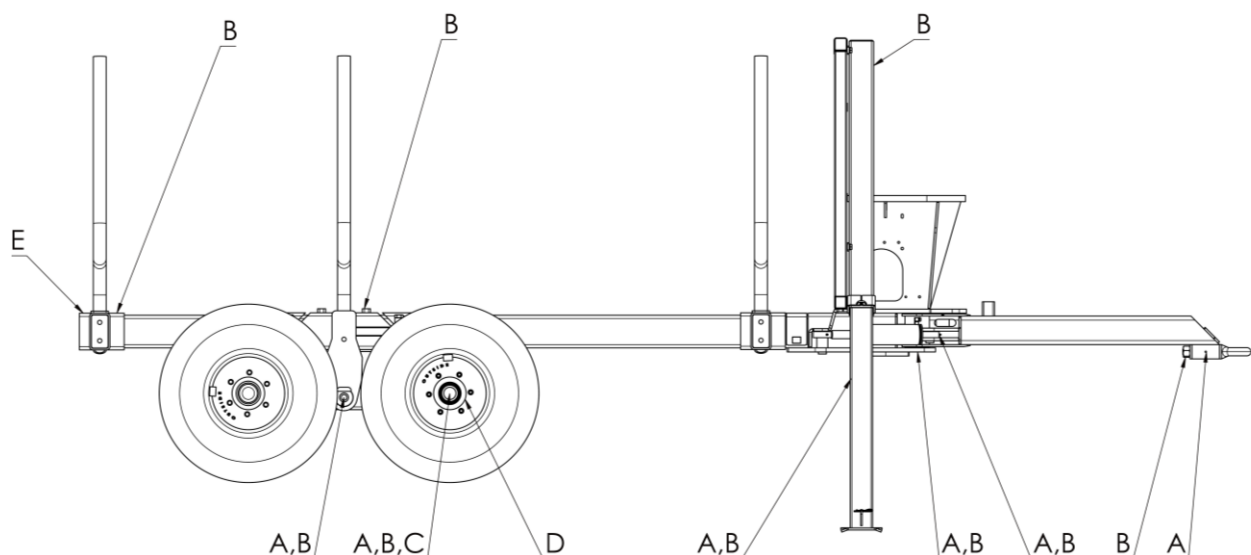

Pos.	Action	Interval in hours			
		10	20	50	100
A	Lubricate with chassis grease	•			
B	Check tightening, locking and that there is no abnormal play		•		
-	Check that no crack or deformation have occurred in material or welding and that no parts have loosened	•			
-	Check that there is no damage or leakage in the hydraulic system	•			
C	<b>Wheel-bearings:</b> check play				•
D	<b>Brakes:</b>				
	Check brake effectiveness				•
	Check the condition of the brake pads				•
	Check that there is no leakage from brake cylinder				•
	Check brakes shoes, it must be more than 5 mm thickness			•	•
E	Check that the lightning is unbroken and operates well	•			

**NOTE:** During the first 50 hours of use, lubricate after every fifth hour of use.

**NOTE:** For bolts and nuts tightening torques see chapter 3.2.

**Check the towing eyelet.**



A towing eyelet with original material thickness of 30 mm must be replaced, if it wears more than 20%. Welding is strictly forbidden on towing eyelet!

## 6 AUXILIARY WHEEL DRIVE SYSTEM

### 6.1 General

Auxiliary wheel drive system is designed to help to drive in forest or off road conditions. System consists of 2 hub-motors and hydraulic/electronic control system. Auxiliary wheel drive system can be powered by tractor's hydraulic system or trailer's on-board hydraulic system. Maximum efficiency is achieved at 300 bar pressure, therefore only trailers with on-board hydraulic system can drive the most effective.

### 6.2 Automatic wheel drive control system

This automatic control system ensures the most effective and safety control. Pressure will be automatically turned off, if the trailer towed too fast or oil flow is too less. This control system prevents hub-motors from damaging.

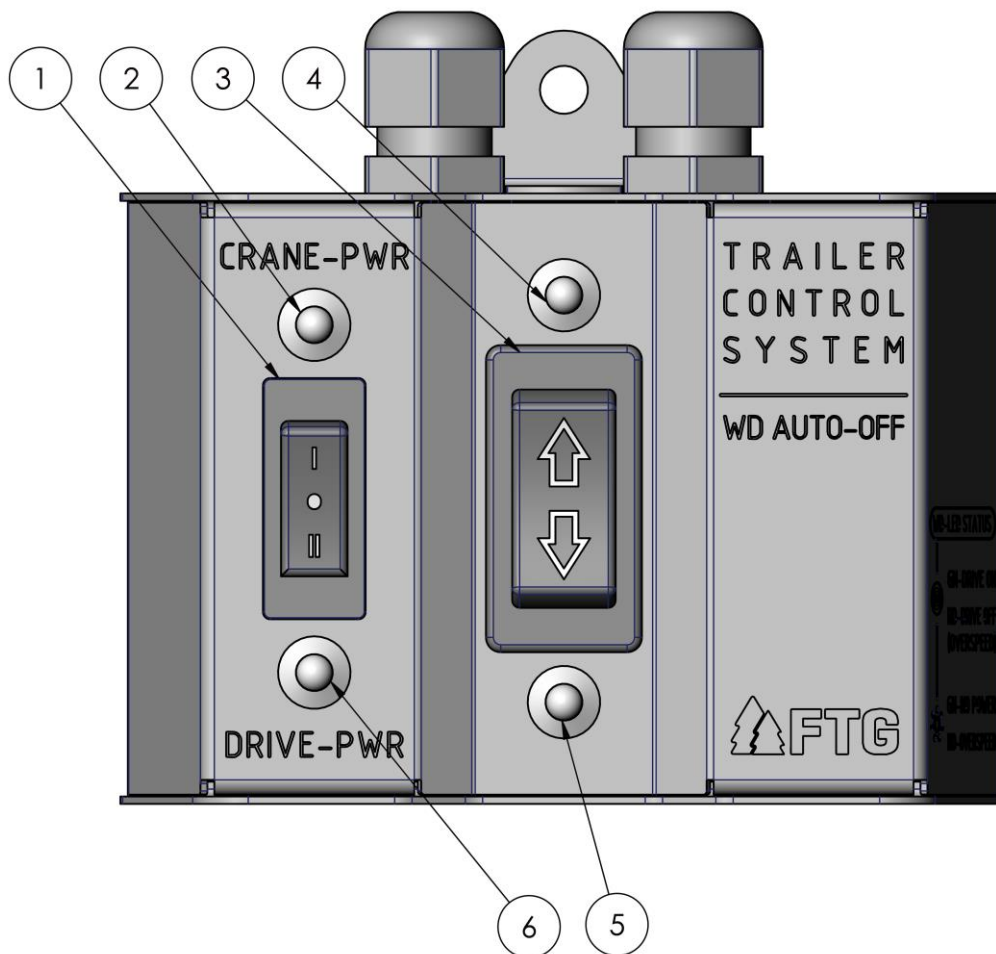

### 6.3 Connecting wheel drive control system

- Connect two hoses “**Drive pressure 1**” and “**Drive pressure 2**” with fast couplings to one of the tractor's double-action hydraulic outlets.
- Connect third hose “**Tank**” directly to the tractor’s oil tank. **There is not allowed any fast couplings, additional filters or other hampers in this line.**  
**DO NOT CONNECT HOSE “TANK” TO TRACTORS OUTLETS!! OTHERWISE HUB-MOTORS WILL BE DAMAGED.**
- Connect the trailer’s tail lights connector to the tractor’s power outlet (12v).

**NOTE:** switch on parking lights to activate control block.



#### **Wheel drive system max. pressure 300 bar.**

Before connecting hydraulic pressure hoses, ensure that pressure output from the tractor will not exceed more than 300 bars – otherwise hub motors or other hydraulic components will be damaged.

### 6.4 Operating instructions

- Turn on the switch II (1). Yellow LED (6) indicates wheel drive system “on/off”
- Turn on oil supply or PTO shaft.
- Shift correct gear on tractor.
- Push the button (3) to the direction you want to drive. Green LED (4; 5) indicates “correct pressure in drive system and driving direction”.
- If the trailer is towing too fast, red LED (4; 5) starts blinking and after 5 seconds sound signal and red LED (4; 5) inform that system turned off automatically.
- If you want to start drive after automatic turned off, push the button (3) to direction you want to drive.
- If you want to stop drive, push the button (3) to opposite direction you drive or switch off control unit.
- If you want to turn on the crane, push the button I (1). Yellow LED (2) indicates crane power “on/off”.

**NOTE:** Button (3) is working only to one direction on trailers without on-board hydraulic system. It is necessary to use the lever of tractors valve block, to change trailer's driving direction.



**If you drive too fast, wheel drive system will be turned off automatically!**

If you shift wrong gear, drive too fast or oil pressure reduced, system automatically turn off, to prevents hub-motors from damaging.



# USER MANUAL

---

F O R E S T R Y   E Q U I P M E N T

## TIMBER CRANE



---

*A great day in a forest!*



## Contents

- 1 INTRODUCTION
- 2 BASIC SAFETY INSTRUCTIONS
  - 2.1 Description of warning symbols
  - 2.2 General safety regulations
  - 2.3 Instructions for safe use
  - 2.4 Explanation of the labels on equipment
  - 2.5 Instructions for safe use
  - 2.6 Transport position
  - 2.7 Hydraulic system
- 3 MAINTENANCE AND SERVICE
  - 3.1 General information
  - 3.2 Safety during maintenance and service
  - 3.3 Daily inspection
  - 3.4 Main parts of crane
  - 3.5 Main parts and installation of rotator
  - 3.6 Main parts of grapple
  - 3.7 Lubrication schedule
  - 3.8 Tightening torques
  - 3.9 Storage
- 4 Installation of a crane
  - 4.1 Installing the crane on trailer or 3-P attachment
  - 4.2 Dismantling crane with 3-P attachment from the trailer  
(Models FB70-3P and FB90-3P)
  - 4.3 Test operating the crane

## 1 INTRODUCTION

Congratulations on choosing FTG product. We hope you will be very satisfied with it. We recommend you, read through this instruction manual to familiarize yourself with all the product's parts. This user's manual contains the information needed to look after your forestry equipment. Take time to read it through thoroughly – it will be well spent time.

The user's manual describes the construction of the equipment, it's maintenance and how it should be handled. Follow the advice and instructions carefully. This will provide the best possible conditions for safe and reliable use and for the factory warranty to be valid. If major repairs are needed, never hesitate to contact your service workshop, which will have the resources and knowledge necessary to help you with any difficulties.

Inspect your product on delivery. If it has been damaged during delivery or transport, or if any parts are missing, contact your dealer.

We reserve the right to make modifications to the equipment, data and the user's instructions without prior notice.

**Good luck with your new FTG equipment!**



**Factory warranty – follow the user instructions!**

## 2 BASIC SAFETY INSTRUCTIONS

### 2.1 Description of warning symbols

The terms "Warning" and "Note" are used regularly in this user manual to alert reader about important information. These terms are used as follows:



**A very important item of safety information. It's indicates risk of serious or fatal injury or serious damage to equipment.**

**NOTE:** Indicates tips and suggestions for making operations easier and/or faster. This information is not safety-related.

### 2.2 General safety regulations



**Carefully read through this user manual and crane's technical data before using the equipment.**

The employer must ensure that:

- The user has read these instructions before using the crane
- These instructions are available at the work site.
- The local regulations and government requirements, regarding the operations, are known and followed.
- User must take care, that nobody is within the safety zone (20 m).

Operating a crane requires a high level expertise to perform operations, as well as knowledge about the machine you are using. If you follow the indicated safety regulations and the crane's technical data, neither the user's nor the machine's safety are put at risk.

### 2.3 Instructions for safe use



**Unauthorized persons are forbidden to enter the machine's risk zone of 20 m.**



If the hydraulic system relief valves are accidentally manipulated, or if the system's functions are changed in any other way, safety cannot be guaranteed under any circumstances and warranty is violated.



Never leave the tractor cab unless the tractor's parking brake is applied and the engine is switched off.

- Always operate the crane from the tractor cab or from another protected operator area that guarantees safe operation.
- Ensure that the machine is standing on secure ground and underlying surface is stable enough to support maximum possible load.
- Ensure that distance between crane and low voltage power lines is more than 2 meters and high voltage power lines more than 6 meters.
- Nobody may stand under the hanging load.
- Never run hydraulic functions to end-points at full speed.
- Never use the crane during transportation.
- The pump system must be switched off during all repairs, connections or disconnections to hydraulic system.
- Crane tip must stand on the ground during all repairs / services.
- Always use tractor's parking brake when loading or unloading.
- Crane must be parked leaning on trailer or the load.

## 2.4 Explanation of the labels on equipment



### Warning sign and user manual label

User must read entire user manual carefully before starting to use the equipment.



**Label for use of safety equipment**

These labels inform the user to employ appropriate safety equipment.



**Warning of suspended load**

This label warns against standing under working crane.



**Warning of remotely started machine components**

The label warns that winch can be started without anybody being nearby or in contact with crane. Ensure that nobody is within the risk zone, before starting this function.



**Risk zone of 20 m**

Unauthorized persons are forbidden to enter the machine's risk zone of 20 m.

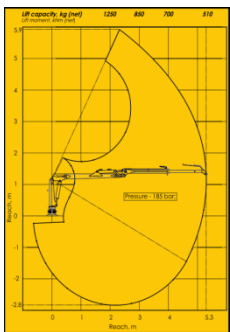

**Lift capacity movement pattern diagram**

Crane is supplied with it's lift capacity movement pattern diagram to inform the user about admissible loads.

TYPE: CRANE TYP: KRAN	FB63T
YEAR OF PRODUCTION BAUJAHR	123456
SERIAL No. SERIENNUMER	12345678
WEIGHT (BRUTTO), kg GESAMTGEWICHT (BRUTTO), Kg	12345
LIFT CAPACITY AT MAX. REACH (NET), kg HUBLAST BEI MAX. AUSLAGE (NETTO), Kg	1234
NOMINAL PRESSURE NENNDRUCK	185
DŪMU st. 3 LT-11119, VILNIUS, LITHUANIA Tel.: +370 5 246 23 20 WWW.FTGBALTIC.LT	

**Manufacturer's ID plate**

Equipment supplied with an ID plate. It states the serial number, year or production, model name, max. working pressure and other information (if applicable).

## 2.5 Instructions for safe use



**Unauthorized persons are forbidden to be in the crane's risk zone of 20 m.**



**If the hydraulic system overload protection devices are accidentally manipulated, or if the system's functions are changed in any other way, safety cannot be guaranteed under any circumstances.**

- Never stand or walk under suspended loads.
- Ensure that the tractor and trailer are standing on secure ground and underlying surface is stable enough to support maximum possible load.
- Only use original grapples and buckets or other correctly dimensioned lifting devices adapted to the crane's lifting capacity. The grapple must be capable of gripping the entire diameter of the log and close securely around the load.



**Always take care when working near power lines. Keep recommended safety distance. If the crane comes into contact with powerline:**

- Do not touch any metal parts.
- Warn everyone in vicinity not to touch the machine.
- Move the crane's boom away from live power lines – be sure not to touch any metal parts.
- After an incident, crane should be checked in authorized service.



**When there is a risk of overturn, immediately lower the main boom to the ground.**

## 2.6 Transport position

- When the trailer is not loaded, crane's booms must be parked as low as possible on the trailer. Take care that the grapple is strictly locked on a trailer.
- Ensure that none of additional equipment on the crane can cause accidents during transport.

**NOTE:** keep in mind the height of the machine when driving under flyovers.

The cranes are purely loading cranes and must not be used as pull cranes or skidding grapple.

The crane stands on the slewing gear and there is no upward pulling force during normal work. For this reason, the crane column is only secured against pulling out with a lock ring. That's why:

- Never pull the crane from top to bottom!
- For example, no disturbing branch above the crane may be pulled down and torn off. The trailer must not be lifted with the crane!

**Otherwise there is a risk of pulling the crane upwards out of the slewing gear.**

- The main boom must never be put on at work. When the main boom is placed on a stake

or on the wood and is then to be lifted, the crane column is loaded upwards and **there is a risk of pulling the crane upwards out of the slewing gear.**

- If the crane is placed on the loaded timber of the logging trailer after work, it must not be pulled down forcefully. **Otherwise there is a risk of pulling the crane upwards out of the slewing gear.**

## 2.7 Hydraulic system

The crane's hydraulics normally requires no servicing. However, the oil and filter should be changed at specified intervals to ensure smooth operation. When replacing hydraulic components, this should be carried out in such a way that no dirt enters the system.



**The crane's hydraulic valve is equipped with a pressure regulator and shock valves to prevent overloading of the crane. This equipment may not be modified in any way.**

**NOTE:** there is strictly forbidden to release oil onto the ground or into watercourses.

**NOTE:** never mix oils of different types or marks in hydraulic system.

- Hydraulic hoses and pipes must always be kept in good condition. All damaged hoses or other components must be replaced.
- Do not operate hydraulic functions at full speed from one end position to the next – otherwise you can damage hydraulic seals and other parts.

## Hydraulic hose ruptures



**In the event of a sudden oil leak, e.g. if a hose breaks, immediately release the joysticks and press the emergency stop button or turn-off the engine.**

- If the event of rupture, you must immediately switch off the tractor's engine and lower the load to the ground. Disconnect the hydraulic flow and repair the rupture. Take care to clean up oil from all parts, devices and ground.

## Working in extreme conditions

Recommended environment working temperature for the crane is  $-25^{\circ}\text{C}$  to  $+40^{\circ}\text{C}$ . Remember – when working under extreme conditions, work with smaller loads than normal. Before working in cold conditions, always warm up the machine. Let the hydraulic oil to circulate freely for a couple of minutes. During hot conditions, take care about the temperature of hydraulic oil. Maximum temperature of an oil can not exceed  $80^{\circ}\text{C}$ . Otherwise the crane may stop work, because the seals and hoses can be damaged.

# 3 MAINTENANCE AND SERVICE

## 3.1 General information

To maintain the crane's excellent operating properties and ensure a long service life, the individual components should undergo regular maintenance. Carefully follow the instructions in this section.

- Clean the crane with water before service and repairs. Take care not to spray electrical components with high-pressure cleaning equipment.
- After all service works, check that everything is correctly connected and test the crane.
- When dismantling the crane's parts, mark each part to facilitate re-assembly after repairs.
- Use only original spare parts.

## 3.2 Safety during maintenance and service

- Always use quality tools.
- Always wear protective clothing and other equipment.



- During service or maintenance work, the tractor's engine must be switched off and the crane should be lowered to the ground.
- Take care with oil that is hot and under high pressure. It can cause burn injuries.

### **3.3 Daily inspection**

- If you see any cracks or damages on crane's supporting parts, operation must be stopped immediately.
- Worn bolts and screws can cause accident when crane is working.
- Check hydraulic hoses, pipes and other components for leaks. Leaking hydraulic fluid makes a risk of accident.
- Check that all bolted joints are fully tightened.
- Check oil level in slewing system and additional hydraulic system. Oil level must be in the middle between maximum and minimum limits.
- Lubricate as specified in chapter 3.7

### **3.4 Main parts of crane**

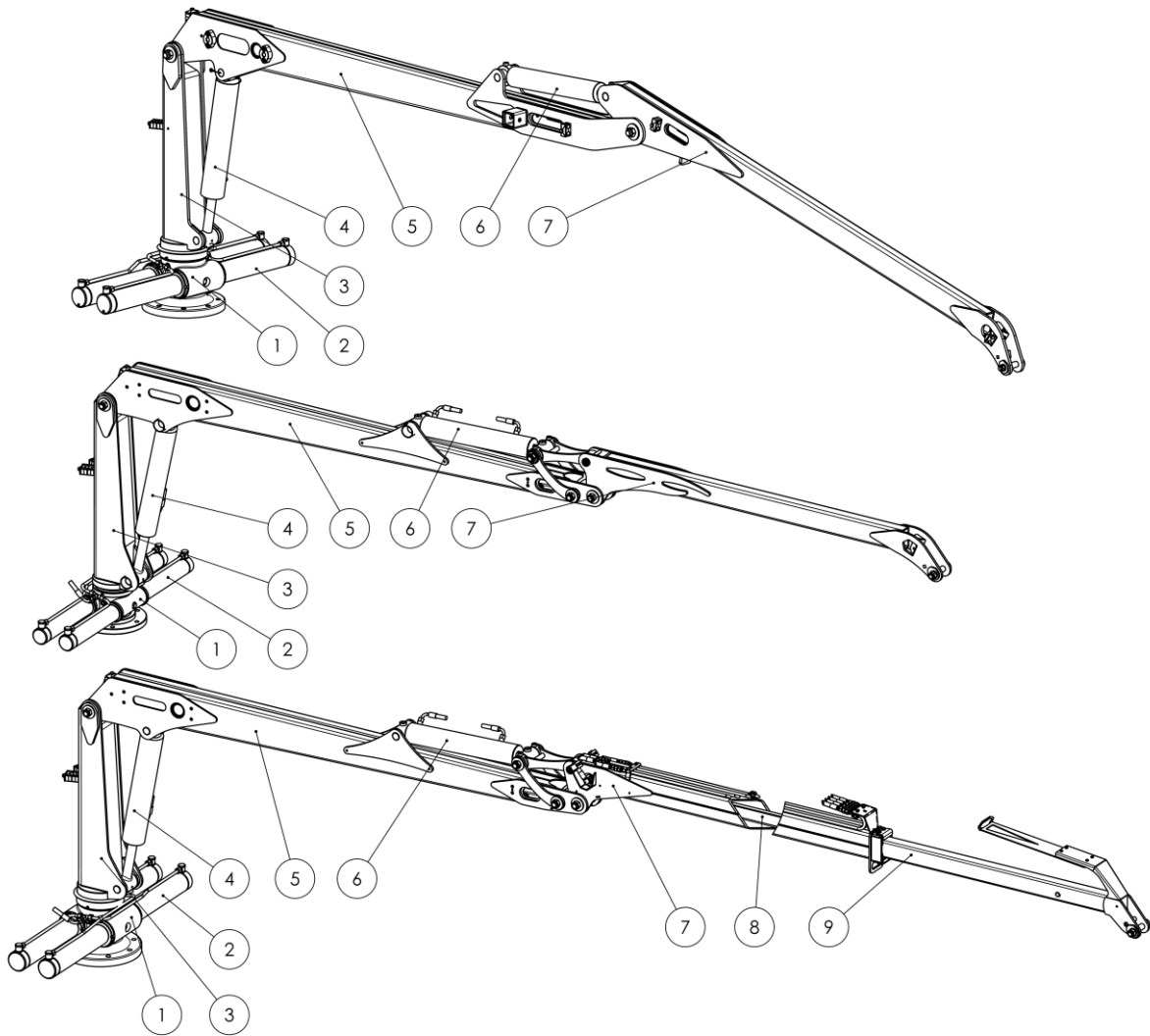



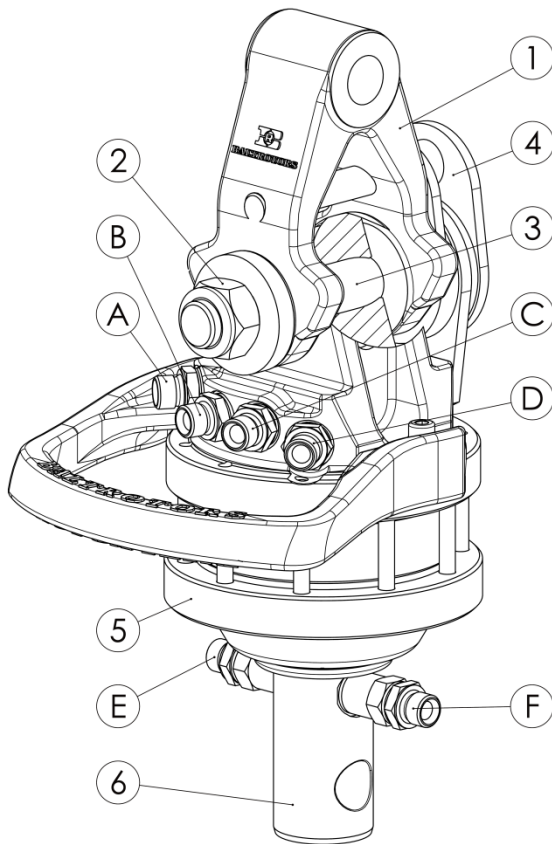

Pos.	Description
1.	Crane base with slewing system
2.	Slewing cylinder
3.	Crane column / pillar
4.	Lift cylinder
5.	Main boom
6.	Jib cylinder
7.	Second boom
8.	Telescopic cylinder
9.	Telescopic boom

### 3.5 Main parts and installation of rotator



Pos.	Description
1.	Link
2.	Adjusting nut
3.	Axle link/rotator
4.	Pending brake
5.	Rotator shaft
6.	Rotator

#### Installation

- Push down the rotator shaft in the grapple socket.
- Assemble the bolt and lock washer.
- Connect the hoses as shown in picture:
  - A – Grapple open
  - B – Rotation clockwise
  - C – Rotation counterclockwise
  - D – Grapple close
  - E – Grapple open 
  - F – Grapple close 
- The grapple hoses should be connected to the lower connection points at the rotator.
- The grapple cylinder's opening side to the port at the rotator shaft marked with "open" 
- Connect the grapple cylinder's closing side to the port at the rotator shaft marked with "close" 

### 3.6 Main parts of grapple

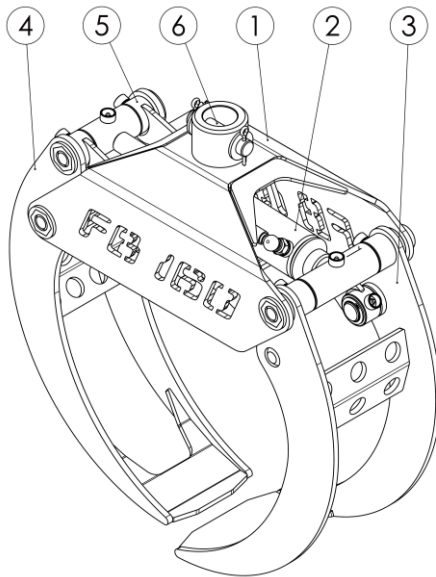

Pos.	Description
1.	Frame
2.	Cylinder
3.	Outer tong
4.	Inner tong
5.	Link
6.	Axle

### 3.7 Lubrication schedule

Follow the service schedule below. Make sure that the axles are unloaded during lubrication – this ensures a good effect of the lubrication. Also clean the grease nipple before lubrication.

Pos.	Lubricating point	Interval
1.	Turnhouse bearing	20h
2.	Articulated joints	50h
3.	Articulated joints	50h
4.	Rotator / link	50h
5.	Grapple	20h
6.	Telescope's wearing surfaces	50h

**NOTE:** Transmission oil in slew motor should be changed first time after 500 hours or 1 year. Later, every 2000 hours or every 5 years.

**Lubrication material:**

- Factory default hydraulic oil is ISO46 (-25°C-+90°C)
- Factory default transmission oil is 80W-90
- Factory default lubricating grease is ISO 6743-9

**NOTE:** During the first 50 hour of use, lubricate after every 5 hours of use.

**Lubrication points location presented for 2-arms crane without a linkage system**

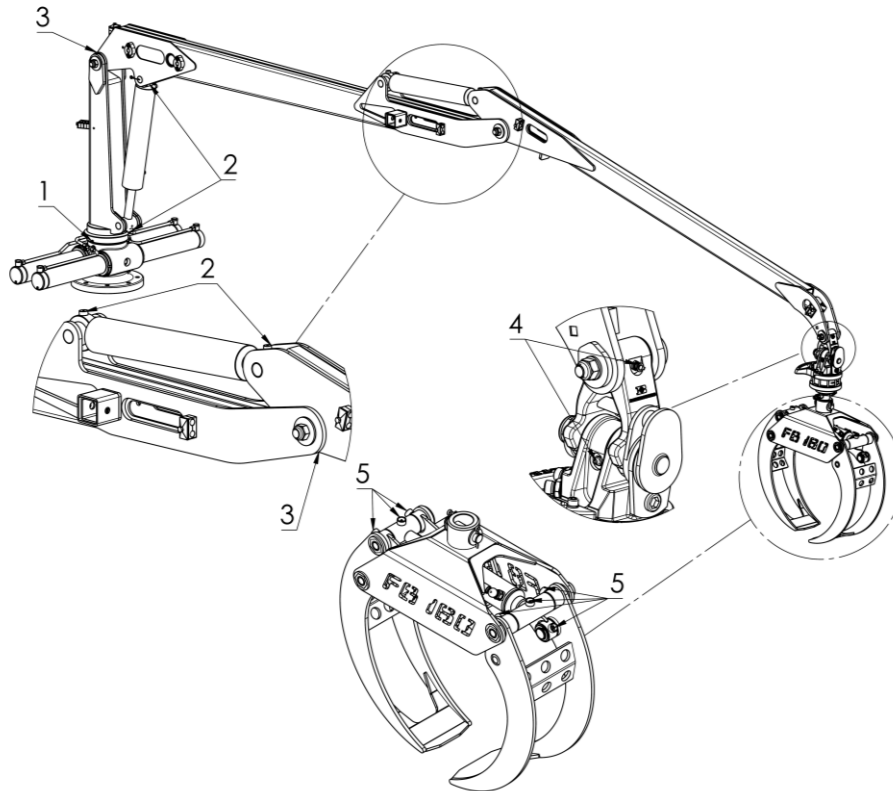

**Lubrication points location presented for 3-arms crane without a linkage system**

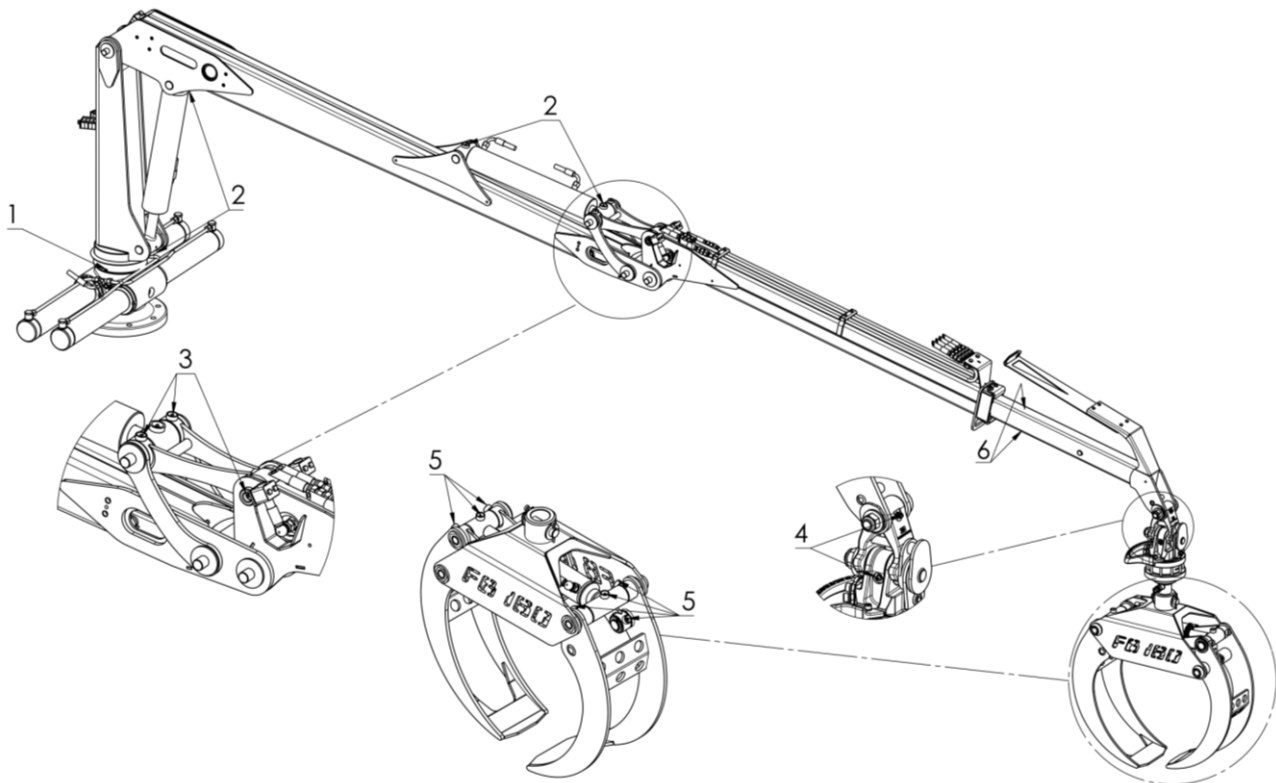

### 3.8 Tightening torques

All bolts and nuts should be inspected and tightened after each 10 hours of operation. Allowable torque range max.  $\pm 5\%$ .

Thread	Class 8.8	Class 10.9	Class 12.9
<b>M5</b>	5,7 Nm	8,1Nm	9,7 Nm
<b>M6</b>	9,8 Nm	14 Nm	17 Nm
<b>M8</b>	23 Nm	32 Nm	39 Nm
<b>M10</b>	46 Nm	64 Nm	77 Nm
<b>M12</b>	80 Nm	112 Nm	135 Nm
<b>M14</b>	125 Nm	180Nm	210 Nm
<b>M16</b>	190 Nm	270 Nm	330 Nm
<b>M18</b>	270 Nm	370 Nm	460 Nm
<b>M20</b>	380 Nm	530 Nm	640 Nm
<b>M24</b>	665 Nm	935 Nm	1100Nm

### 3.9 Storage

If the crane is not to be used for a long time, it is important to clean the crane and fill up all lubrication points, as well as lubricate all visible parts of piston rods with suitable lubricant or preservative. To prevent the risk of rust inside the turnhouse cylinders, it is recommended to fill transmission oil up to the fill-in plug. Do not forget detract the oil from a turnhouse till nominal level before use. During the cranes long storage the angle of incline must not be more than 25°.

## 4 Installation of a crane

### 4.1 Installing the crane on trailer or 3-P attachment

The crane is usually delivered fully assembled including hydraulic valve block. The crane is ready to be installed on 3-P attachment, trailer, or other machine.

- Ensure that trailer or 3-P attachment is stable standing on the ground and it will not overturn during installation.
- Clean the base plate and the underside of slew motor. Lift the crane with an overhead/gantry crane.
- Match the holes in base plate with the holes in the crane slew motor, check that the slew motor housing is correctly positioned. Fit the bolts and lock nuts and tighten with the right torques – see table (chapter 3.8).
- Connect the stabilizers' hydraulic hoses to the crane valve, following the hydraulic diagram.
- Make sure the quick couplings are clean, to prevent dirt from entering the system.
- Connect the hydraulic valve's return hose first and then connect the pressure hose to the hydraulic system.
- Valves block to be mounted on the best possible place on the tractor.

**NOTE:** The hydraulic high pressure hoses may not be placed inside the tractor cabin.

#### **Dismantling crane with 3-P attachment from the trailer (Models FB70-3P and FB90-3P)**

- Lay-down the drawbar and the grapple on the ground.
- Remove/release axles and bolts used to fix 3P attachment.
- Carefully lift-up 3P attachment ~150mm using support legs.

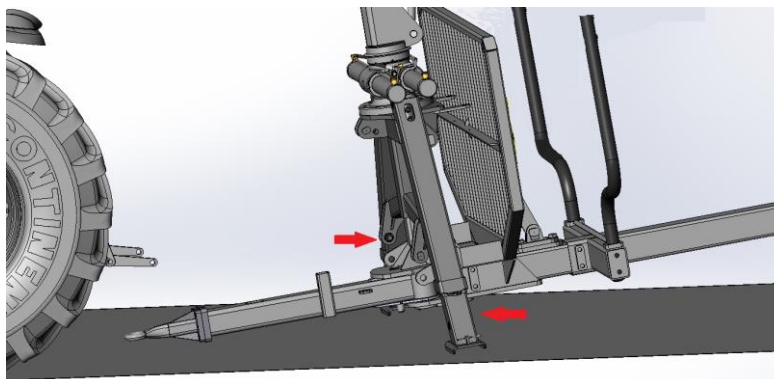

**NOTE:** under any circumstances do not lift-up the unit more than max. 200mm to avoid undesired fall down!

- Hitch 3P attachment to the tractor.
- Lift-up the 3P attachment carefully as much as necessary (approx. 400mm) to disengage it from the trailer central guide column.
- Ensure all hydraulic and electrical lines are disconnected and crane is in suitable position before moving away from the trailer.

**NOTE:** proceed all steps in backward order to mount 3P attachment back on trailer. Be sure to install/secure all axles, bolts hydraulic and electrical lines prior to operation.

## 4.2 Test operating the crane

### 4.2.1 Before test operating

Check the following points before taking the crane into use for the first time or after standing for a long period.



**Check oil level in the turnhouse. If it is filled up to the plug, then detract the oil to nominal level before use.**

- Lubricate the crane according lubrication schedule.
- Check that all bolts are tightened. For tightening torques see chapter 3.8.
- Before connecting the hydraulic lines, ensure that the joysticks/levers are in the neutral position.
- Check that the pressure and return hoses are correctly connected and are not leaking. If any problems arise, contact your dealer.
- Check that all hydraulic hoses are in good condition and there are no damages.
- If necessary, top up the hydraulic oil to the right level.



**Ensure that the trailer stands on the stable ground during test run. Both support legs should always be used when crane is operating.**



### 4.2.2 Operating instructions

Further instructions are valid for FRV60/8-2 lever (3-coord.) valve block (standard), but can also be applicable to other control types (joysticks with el. on/off).

#### EXERCISE 1: "One lever at a time"

The tractor should have a constant rpm. Begin with one lever at a time. The left hand operates left 3-coord. lever (for crane slew, main (first) boom up/down and telescopic boom inside/outside). The right hand operates right 3-coord. lever (for second boom, rotator and grapple), while 2 middle levers are for support legs. Functions are located as shown below. Try all the functions step-by-step to accommodate with machine reaction.

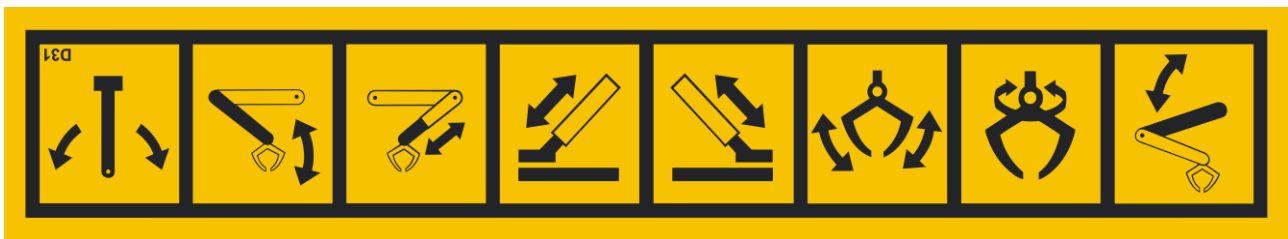

Slew	Second arm	Telescopic arm	Support leg	Support leg	Grapple	Rotator	First arm
"A"	"B"	"C"	"D"	"E"	"F"	"G"	"H"

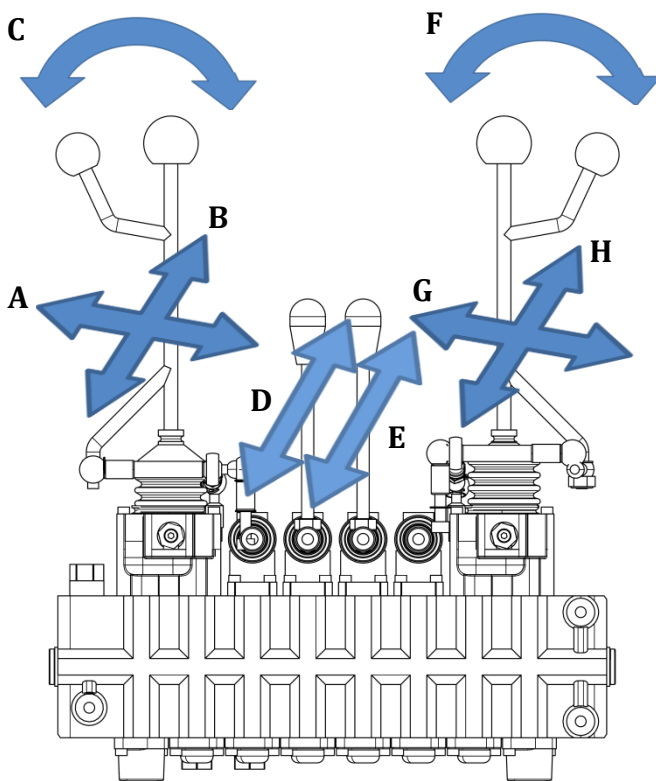

- A – Slew (left/right)
- B – Second arm (lift up/down)
- C – Telescopic arm (move inside / outside)
- D – Left support leg (lift up/down)
- E – Right support leg (lift up/down)
- F – Grapple (open/close)
- G – Rotator (turn left/right)
- H – First arm (lift up/down)

Valve block FRV60/8-2lever (3-coord.)

### **EXERCISE 2: „Parallel movements“**

Once the above is mastered, i.e. that the operator's hands „find“ right lever and can start and stop the crane movements gently, it is a time to try to combine movements.

**NOTE:** The pump capacity may limit the number of movements which can be made simultaneously.

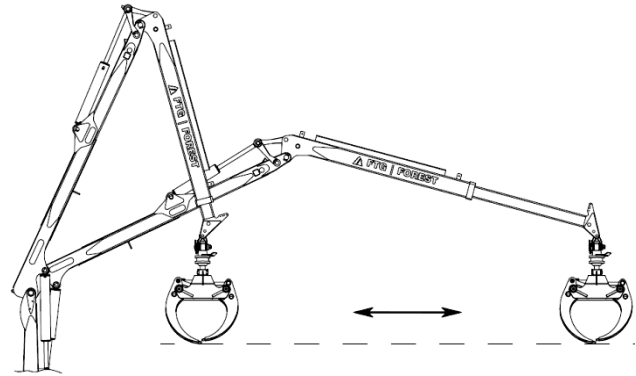

Hold the grapple about 50 cm above the ground, as far from the trailer as possible, with the crane slewed 90° in relation to the trailer. Practice moving the grapple in towards the trailer and back out again, parallel to the ground. Operate the main boom with the left hand and the outer (second) boom with the right one at the same time. Remember to start and stop all movements gently.

### **EXERCISE 3: „Both left hand levers at the same time“**

Straighten out the crane boom and place the grapple on the ground as shown. Operate the main boom and the slewing at the same time. Lift the grapple over the stakes and place it on the ground on the opposite side of the tractor. Use only the left hand for this operation. Practice the above until the grapple can be moved smoothly, without swinging. Try also to place the grapple in an exact position on the ground. Begin the exercise very slowly and then increase the speed gradually as the competence improves.

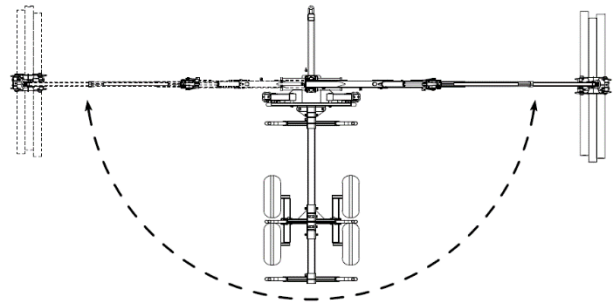

### **EXERCISE 4: „Loading and Unloading“**

Lay out a suitable „bundle of timber“ as shown. Grip the bundle with the grapple, choosing a gripping point so that lowest part of the bundle leans against the gate. Lift a little as the grapple closes on the timber – this makes the logs roll into the grapple more easily.

**NOTE:** Do not expose the rotator to pressure or bending stresses.

Then lift the timber a little and move it towards the trailer before beginning the main lifting and slewing movement – this decreases the risk for the trailer to overturn.

If necessary, the bundle of timber can be made more even in length by opening the grapple very slightly and at the same time pushing the timber against the gate with the outer boom.

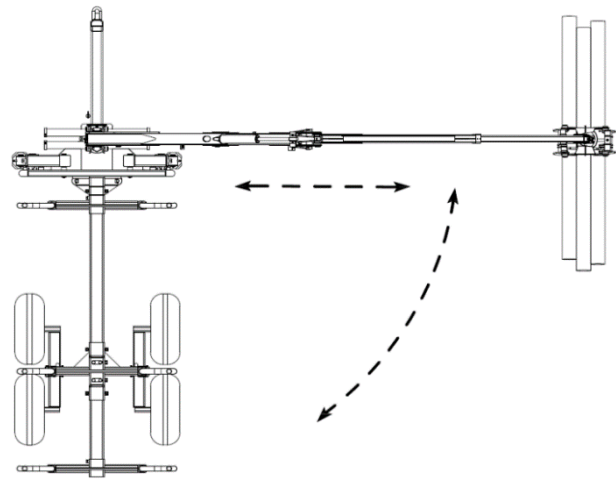

When unloading, as soon as the timber has been lifted over the posts, lower it towards the ground before moving it outwards from the trailer. This reduces the risk of the trailer to overturn.

Practice all exercises until all the movements will become under full control and the grapple will move smoothly, without swinging. It is important the all exercises are carried out calmly and methodically, so that a smooth and safe movement pattern is practiced.

It is usual for a person to spend weeks or months of regular practice before they fully master the technique of crane operation.

The risk of accidents is greater during the training period. It is easy to move the wrong lever so that the timber glides out of the grapple – make sure there is plenty of space around and no bystanders are near who could get hurt.

**NOTE: Never leave the tractor cabin before:**

- **The crane is unloaded and fixed.**
- **The tractor's brake is engaged.**

**Loading:** Always use a support legs or the steering drawbar to reduce the risk of overturn during loading.

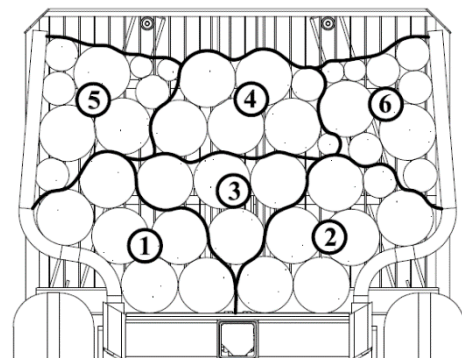

Careful loading makes handling of the timber thereafter easier. E.g. it will be easier to make an even log pile when unloading. Build up the load so that the posts steer up the bundles of timber. Create a concave load profile.

If several bundles of timber lie close to each other on the ground, begin by loading the biggest bundle, then lift together the smaller bundles. In this way the total number of lifts can be reduced and the crane is used more efficiently.

**NOTE:** The trailer's stability factor is lowest at the start of loading.

Ensure that the grapple rests steadily on the loaded timber when moving between loading places. Therefore retain the last bundle of timber in the grapple on the load for transport.

Loading and unloading should be done as close to ground level as possible.

**Unloading:** Always use a support legs or the steering drawbar to reduce the risk of overturn during loading.

It is easiest to get a good grapple „catch“ when unloading if the timber is taken from the sides, close to the posts, first, i.e. creating a convex load profile.

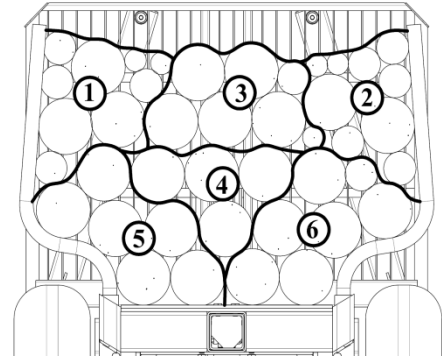

Try to grip the timber at the timber bundle's „center of gravity“ so that the bundle hangs horizontally in the grapple. This will avoid the risk of the timber sliding away and help to make more even pile of logs.

**Log piling**

The log pile is built up with a slight gradient so that the timber will not roll away when the grapple is opened – see fig.

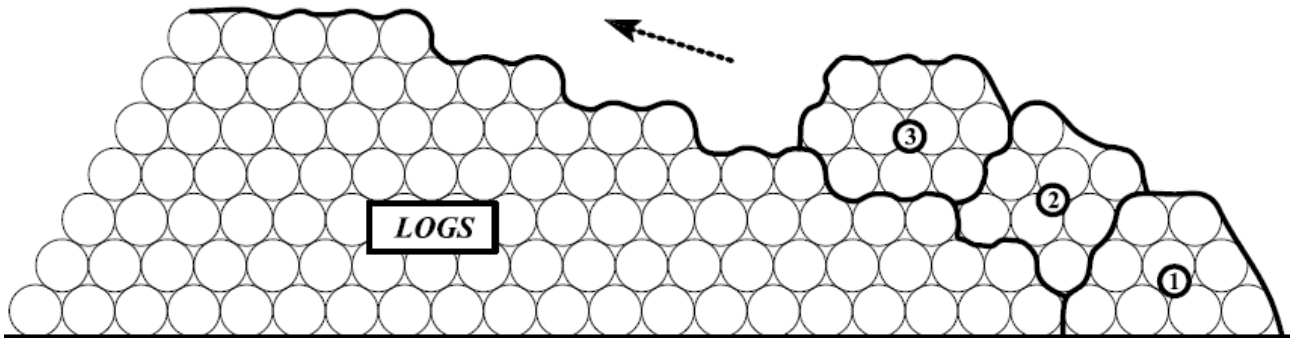

**Always lift with the telescope retract (inside). Never lift the load at full reach.**



# USER MANUAL

---

F O R E S T R Y   E Q U I P M E N T

## VALVE BLOCK & CONTROL SYSTEM

### FRV 60/8 2-Lever (3 coord)



---

*A great day in a forest!*

---



## 1 TECHNICAL DATA

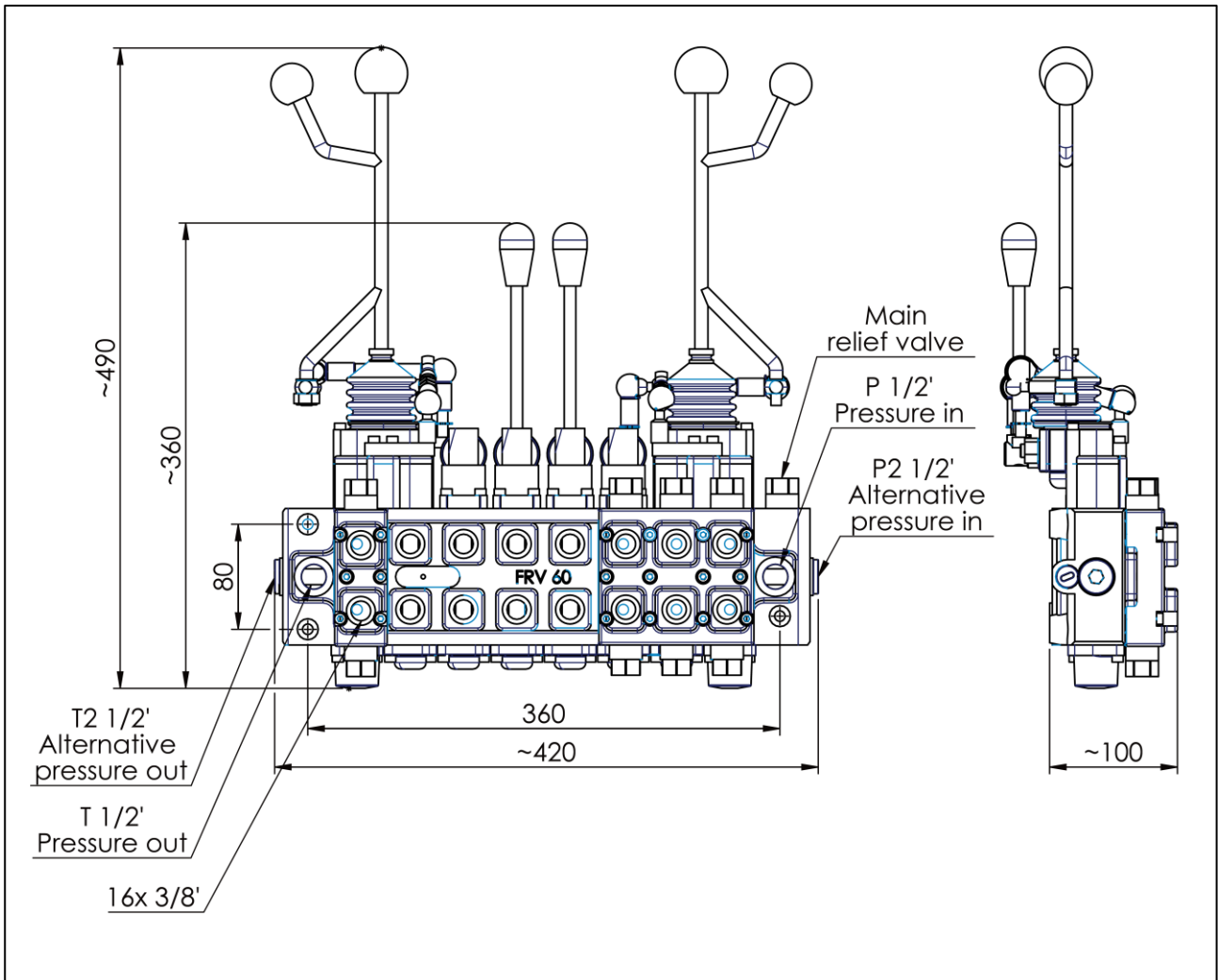

### FRV 60/8 2-Lever (3 coord.) technical data

Highest work pressure, continue	250 bar
Highest current, P=250 bar	60 l/min
Highest return pressure, continue	10 bar
Oil temp. max.	60° C
Oil temp. min.	-20° C



## 2 CONNECTION

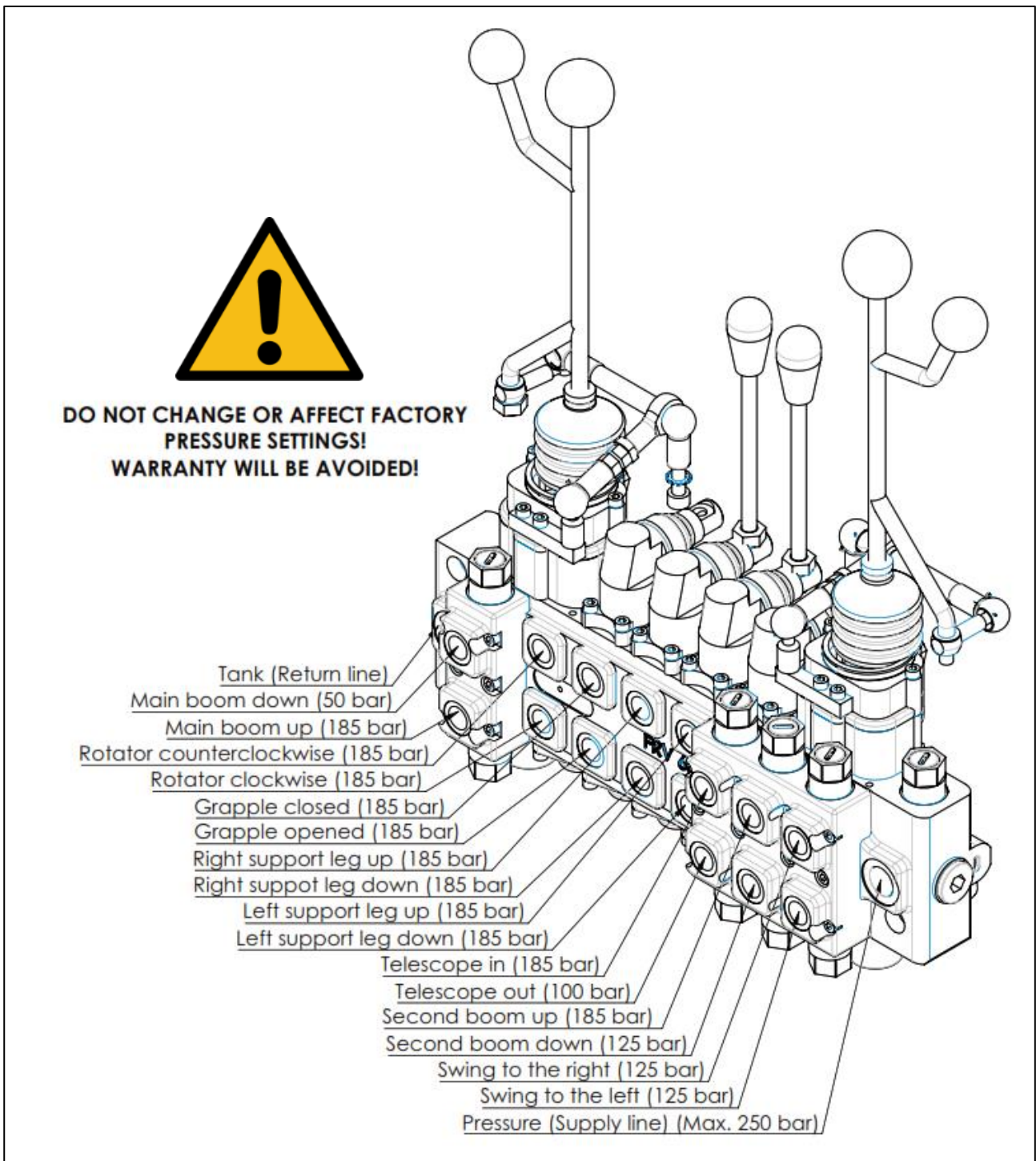

\* Section "Swing to the left", "Swing to the right" pressure is 165 bar for FB51L, FB63T, FB63TS, FB69T-G2 cranes.

### 3 Instructions for safe operation

- Always check that the valve is correctly connected, the levers are in their middle position and hydraulics system switched off before starting the hydraulics.
- Make sure there are no people or objects in the crane's danger zone.
- The control valve may only be used by a skilled operator.

### 4 Transport and storage

All valve hydraulics lines must be protected by protection plugs. Protect the valve against humidity and temperature variations. Protect the valve and control levers against mechanical impacts and loads.

### 5 Valve installation

Ensure crane support so that the crane stays in place even if there is no pressure.

Always install the valve on a sturdy backplate equipped with a lifting handle. The valve control levers are not intended for lifting. Backplates intended for the valves are available from the valve manufacturer.

Clean the hydraulics system carefully prior to installation. Use only hydraulic oils suitable for the purpose, SAE 32 or SAE 46. The manufacturer recommends using SAE 46 for improved operation efficiency. Make sure all hose connectors, threads and seals are in excellent condition. Install the valve return line (T1, T2 or T3) first; connect it straight to the tank. If the valve return line is not connected to the tank, make sure the return line cannot be closed by other valves, quick connectors or stopcocks of the hydraulic system.

Connect crane cylinders to the correct ports (groups 1-8) according to the motions and directions.

**Note!** The sequences and directions provided in the diagram are for reference only and may vary depending on the crane manufacturer and type.

Connect pressure to the pressure line (P1 or P2).

**NOTE!** In case of proceeding from one valve to the next, a serial connection nipple must always be used at port T2.

## 6 Instructions for use

When using the valve and crane, be careful and comply with the crane's safety instructions. During the use, make sure the hydraulics system is not overheated and there is enough oil in the system.

When relocating the unit or the like, switching the hydraulics off from the valve is recommended, thereby avoiding needless loading of the valve and hydraulics system.

If the crane is not in use, always leave the boom system in such position that the cylinders are free of pressure.

Maintenance instructions

Periodically add Vaseline to valve steering swivels: remove the rubber cover and apply Vaseline to

exposed surfaces by brush.

Check the tightness of group stud bolts (25Nm) periodically. Check after the first 8 hours

following commissioning and then every six months.

If the crane lacks power and there is reason to suspect that the problem lies with the valve, the

valve pressures must be measured. Always measure the pressure from the relevant actuator port.

When measuring pressure, the valve adjustment values allowing identification of the actual valve

adjustment pressures need to be used. Only qualified maintenance personnel may carry out valve

re-adjustments.

If the valve is not to be used for a long time, the oil should be kept inside the valve and the levers

moved periodically to ensure that oil film remains on sealing surfaces. In case of long-time

storage, make sure there is no pressure in the valve.

Restrictions on use

The valve may only be used with timber and piece goods lifts and cranes. Use of the valve with

personnel lifts is not allowed.

The valve does not include lock valves or hose burst valves, which means that the valve cannot be

trusted with keeping the load up.

Warranty period

Two years of work in one shift.

Warranty extent and limitations

The warranty covers segmented raw material and manufacturing defects. The warranty does not

cover defects caused by normal wear and tear, negligence, improper use, incorrect installation, or

lack of maintenance.

Any damages discovered must immediately be notified to the manufacturer for determination of

whether they are covered by the warranty.

Under the warranty, damaged components are replaced or repaired, if repairing to a condition

equivalent to new is possible. The warranty does not cover indirect costs or secondary losses.

The owner of the unit shall compensate for the freight and installation costs of the unit/component covered by warranty.

The warranty is not valid if the unit has been modified so that it differs from the original condition,

for example, by structural additions or modifications or use of non-original replacement

components, or if the unit has been opened up without the manufacturer's permission.

The

warranty is valid only if the installation has been carried out by an installation company authorized

by the manufacturer.

7

## 8 GUARANTEE

### GUARANTEE PERIOD

One year.

### OTHER CONDITIONS

The guarantee covers faults that are demonstrably due to faulty materials or workmanship. The guarantee does not cover faults caused by normal wear and tear, neglect, misuse, faulty installation or incorrect repair. Any fault must be reported without delay to the manufacturer in order to establish, if the damage is covered by the guarantee. Manufacturer reserves the right to stipulate that the valve block must be returned to the manufacturer for repair under guarantee. The guarantee covers a replacement part or repair of the part, if the repair results in a part equivalent to a new one. The purchaser of the equipment is responsible for the transportation and installation costs of the equipment/parts under the guarantee. The guarantee is void, if the valve block has been modified so that it differs from the original because of e.g. additional structures, structural changes, or replacement parts which are not original. The guarantee becomes void, if the valve block is resold to the another part during the guarantee period.



F O R E S T R Y E Q U I P M E N T

**USER MANUAL**

# ON-BOARD HYDRAULIC SYSTEM

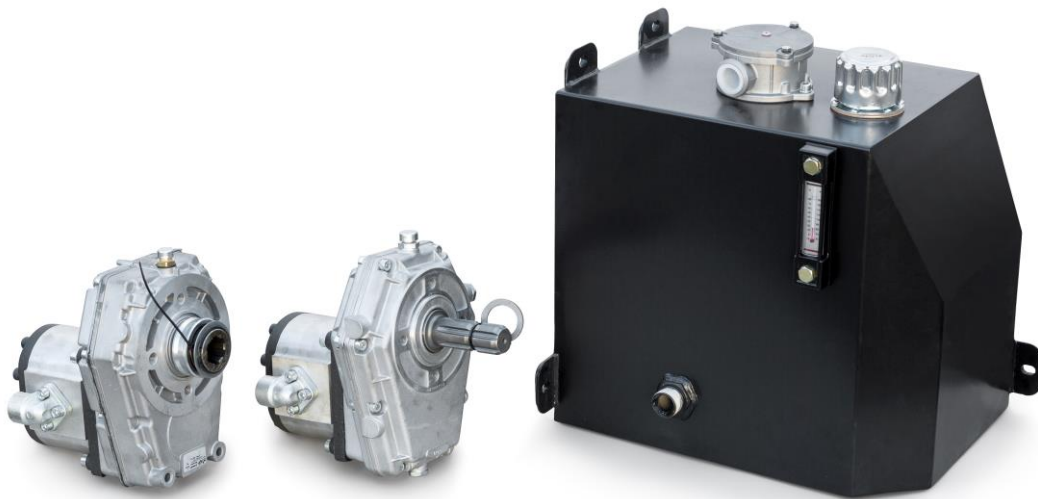

---

*A great day in a forest!*

---

## Contents

- 1 INTRODUCTION
- 2 On-board hydraulic system
  - 2.1 General information
  - 2.2 Safety instructions
  - 2.3 On-board hydraulic system installation
  - 2.4 Operation
  - 2.5 Maintenance



## 1 INTRODUCTION

Congratulations on choosing FTG product. We hope you will be very satisfied with it. We recommend you, read through this instruction manual to familiarize yourself with all the product's parts. This user's manual contains the information needed to look after your forestry equipment. Take time to read it through thoroughly – it will be well spent time.

The user's manual describes the construction of the equipment, it's maintenance and how it should be handled. Follow the advice and instructions carefully. This will provide the best possible conditions for safe and reliable use and for the factory warranty to be valid. If major repairs are needed, never hesitate to contact your service workshop, which will have the resources and knowledge necessary to help you with any difficulties.

Inspect your product on delivery. If it has been damaged during delivery or transport, or if any parts are missing, contact your dealer.

We reserve the right to make modifications to the equipment, data and the user's instructions without prior notice.

**Good luck with your new FTG equipment!**



**Factory warranty – follow the user instructions!**

## 2 On-board hydraulic system

### 2.1 General information

Additional hydraulic system is used when tractor's oil flow is insufficient for desired crane operation speed at idle PTO RPM. Set contains hydraulic pump with a gear box and adapter plate, oil tank with return line filter, oil level and temp. Gauge as well as hydraulic hoses. Gear box may be equipped with a shaft or fast coupling for PTO connection according to custom requirements.

### 2.2 Safety instructions



#### **Risk zone 20 m**

Unauthorized persons are forbidden to enter the machine's risk zone of 20 m.



#### **Warning! Rotating parts.**

Indicates a risk of rotating parts. Be sure never to touch any of rotating components like PTO driven hydraulic pump, wheel drive or similar.

- Use only original PTO shafts for hydraulic pump on drawbar.
- Always fix stop plate, when hydraulic pump mounting directly on PTO shaft.

### 2.3 On-board hydraulic system installation

- Mount the oil tank on trailer or 3P attachment frame as shown in picture.
- Mount the hydraulic pump on drawbar (if the hydraulic pump is male).
- Connect all hydraulic hoses according the hydraulic diagram.
- Fill up hydraulic oil tank till nominal level.
- Connect the hydraulic pump to PTO shaft.

## 2.4 Operation



**Maximum temperature of oil can not exceed 80°C.** Otherwise the crane may stop work, because the seals and hoses can be damaged.

**NOTE:** If accidents or damages occur during operating the hydraulic system, the work must be stopped immediately and repair all damages before using trailer again.

## 2.5 Maintenance

On-board hydraulic system normally requires no servicing. However, the oil and filter should be changed at specified intervals to ensure smooth operation. When replacing hydraulic components, this should be carried out in such a way that no dirt enters the system.



**Never mix oils of different types or marks in hydraulic system.**

**NOTE:** There is strictly forbidden to release oil onto the ground or into watercourses

- Hydraulic hoses and pipes must always be kept in good condition. All damaged hoses or other components must be replaced.

To maintain the on-board hydraulic system excellent operating properties and ensure a long service life, the individual components should undergo regular maintenance. Carefully follow the instructions in this section.

Operation	8 hrs	25 hrs
Check tightening and locks. Check for abnormal play.		X
Inspect goods and welds for cracks, deformations and loose parts.	X	
Check hydraulics for damage or leakage.	X	
Check transmission oil level in multiplier	X	
Check hydraulic oil level in oil tank	X	



## TRAILER FB90

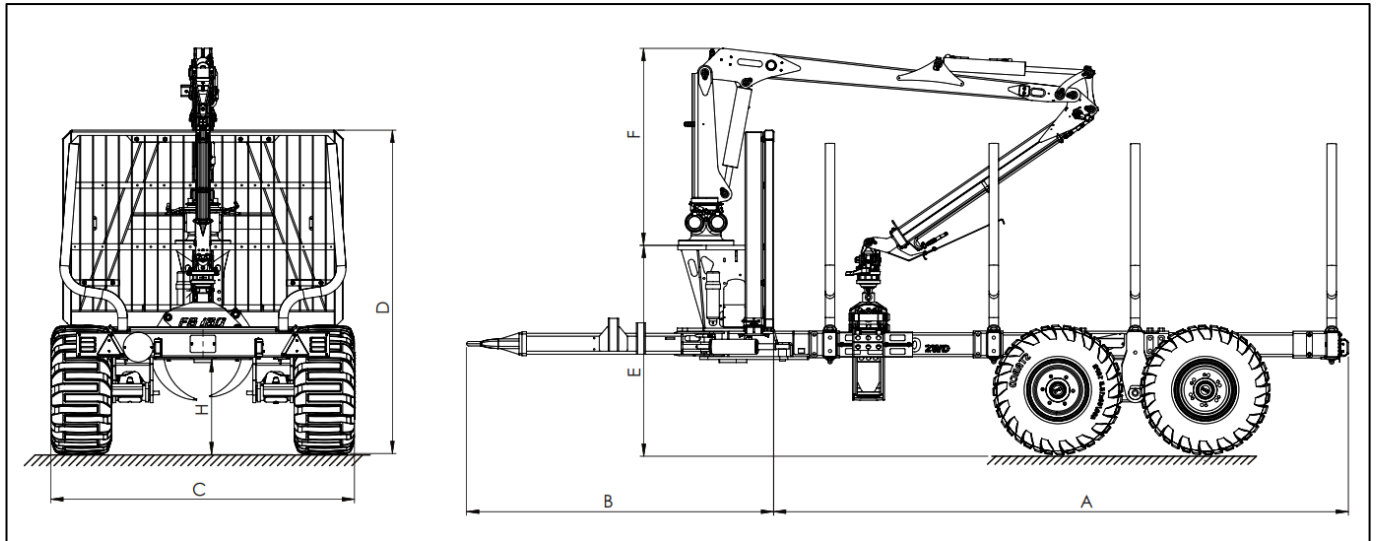

	CRANE	WHEELS	A	B	C	D	E	F	G	H
FB90	FB51L	400/60x15, 5 14 PR	3865-4465	2000-2620	2035	2175	1400	1490	386-959	640
FB90	FB53T		3865-4465	2000-2620	2035	2175	1400	1450	386-959	640
FB90	FB63T		3865-4465	2000-2620	2035	2175	1400	1350	386-959	640
FB90	FB69T		3865-4465	2000-2620	2035	2175	1400	1350	386-959	640

### GENERAL INFORMATION

Load area, m <sup>2</sup>	2
Load capacity, kg	9000
Weight (with standard equipment), kg	1450
Load length, m	370
Central beam dim., mm	160x160x8

## HYDRAULIC DIAGRAM FB90

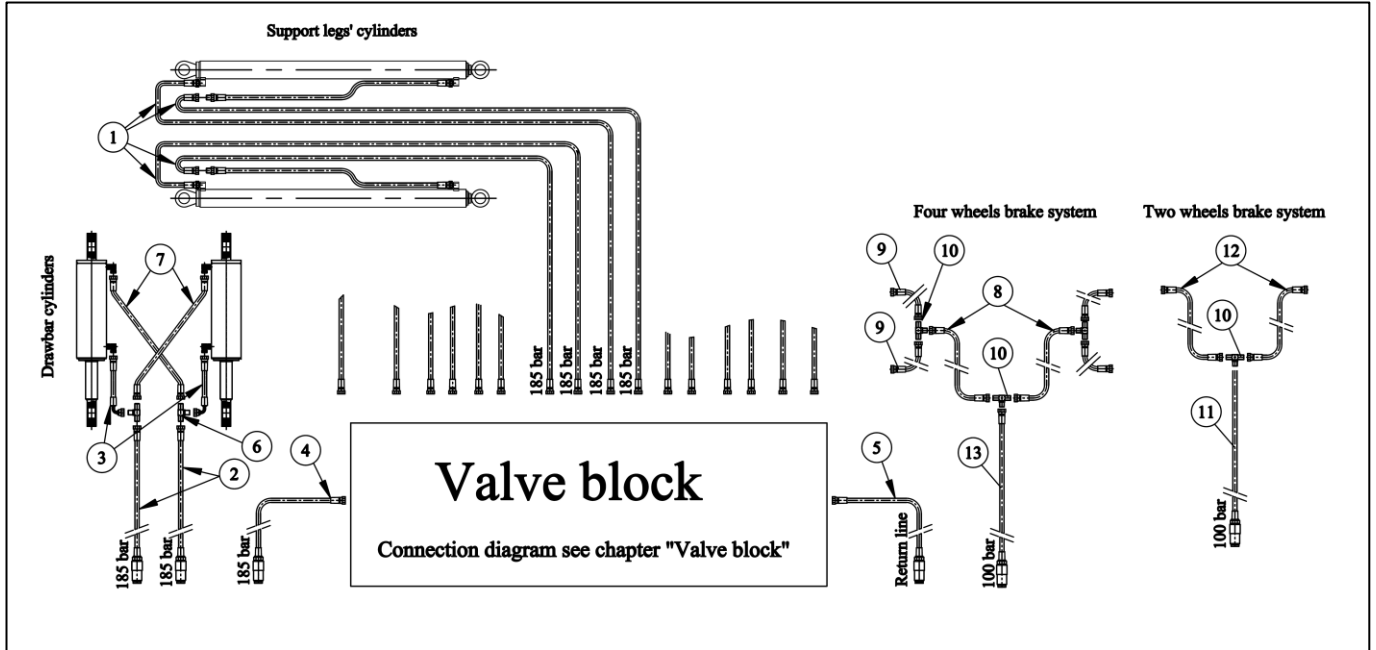

### Hydraulic components

Pos.	Qty.	Description	Mod. Dim.	Drawing No.	Art. No.
1	2	Hydraulic Hose	IR <sup>3/8</sup> -3150( <sup>3/8</sup> )IR <sup>3/8</sup> 90°	-	-
2	2	Hydraulic Hose	IR <sup>3/8</sup> -2600( <sup>3/8</sup> )UR FC	-	-
3	2	Hydraulic Hose	IR <sup>3/8</sup> -430( <sup>3/8</sup> )IR <sup>3/8</sup>	-	-
4	1	Hydraulic Hose	IR <sup>1/2</sup> -3000( <sup>1/2</sup> )-FC <sup>1/2</sup>	-	-
5	1	Hydraulic Hose	IR <sup>1/2</sup> -3000( <sup>1/2</sup> )-FC <sup>1/2</sup> (with valve)	-	-
6	2	Adaptor	UR <sup>3/8</sup> -UR <sup>3/8</sup> -UR <sup>3/8</sup>	-	-
7	2	Hydraulic Hose	IR <sup>3/8</sup> -630( <sup>3/8</sup> )IR <sup>3/8</sup>	-	-
8	2	Hydraulic Hose	IR <sup>1/4</sup> -1950( <sup>1/4</sup> )-IR <sup>1/4</sup>	-	-
9	2	Hydraulic Hose	IR <sup>1/4</sup> -600( <sup>1/4</sup> )-IR <sup>1/4</sup>	-	-
10	1	Adaptor	UR <sup>1/4</sup> -UR <sup>1/4</sup> -UR <sup>1/4</sup>	-	-
11	1	Hydraulic Hose	IR <sup>1/4</sup> -5300( <sup>1/4</sup> )-FC <sup>1/4</sup>	-	-
12	2	Hydraulic Hose	IR <sup>1/4</sup> -1950( <sup>1/4</sup> )-IR <sup>1/4</sup>	-	-
13	1	Hydraulic Hose	IR <sup>1/4</sup> -3700( <sup>1/4</sup> )-FC <sup>1/4</sup>	-	-

**WHEEL DRIVE SYSTEM DIAGRAM**

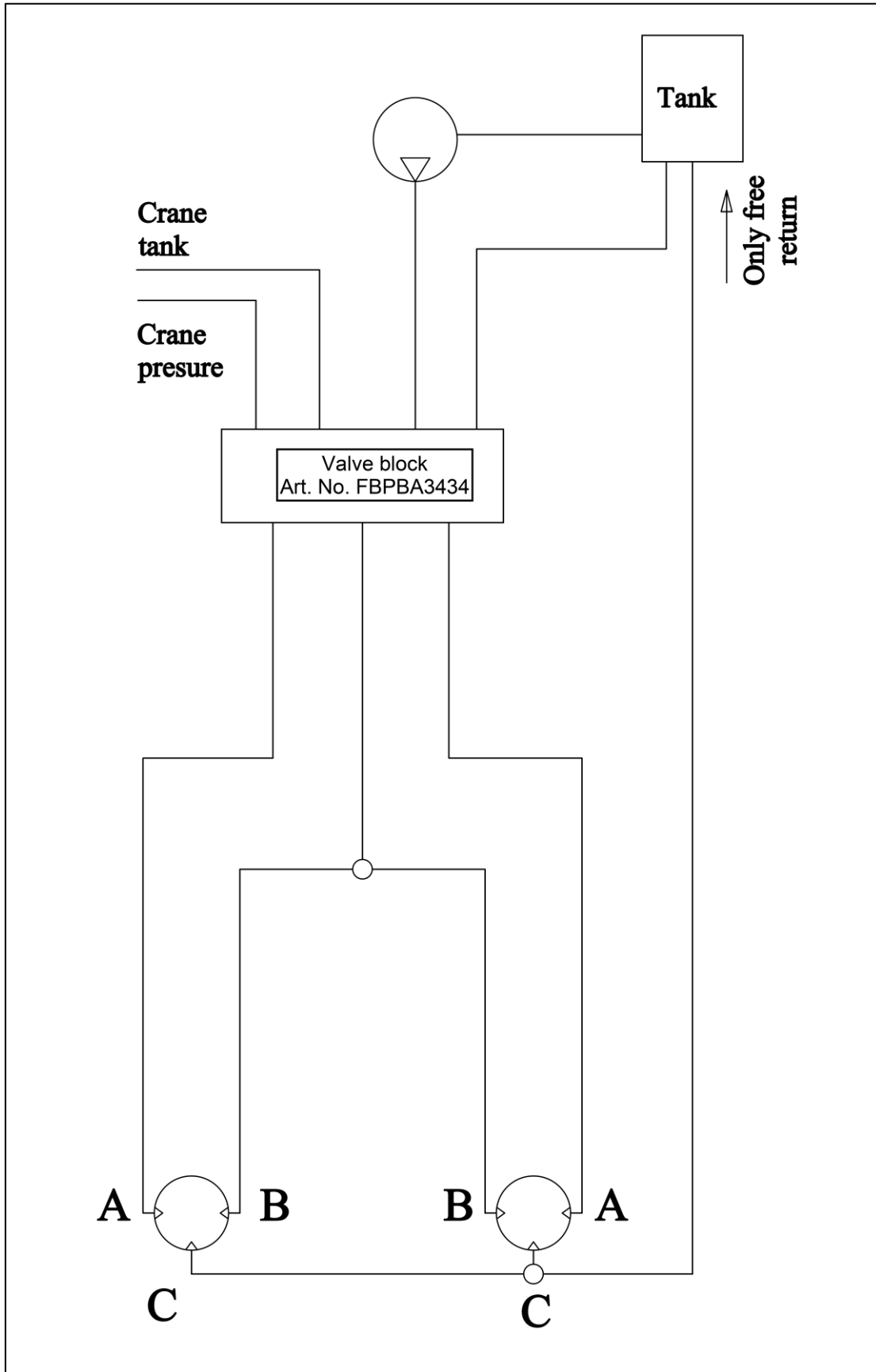

**REAR LAMP WIRING DIAGRAM**

