

FB50D

Discover the pleasure of performance



Trailer FB50D

FTG Källefäll trailer FB50D provides a loading capacity up to 5000kg and a permissible total weight of 7 000 kg.

FB50D is a compact one axle timber trailer with a crane selection from 4,2m up to 6,3m of reach. It is suitable for the transportation of firewood, pulpwood, and other timber logs.

Standard trailer FB50D has a double beam frame, fixed straight drawbar, solid crane base with hydraulic telescopic support legs, sling loops for tension belt, integrated LED lights, and plate number lights, fixed 4 bunks with 8 stakes, and 12.5/80–15.3 wheels.

To suit every users' specific needs and extend the areas of use FB50D trailers have a broad range of options and accessories.

FB50D combined with FTG Källefäll forest cranes offers high reliability and efficiency. Demand for maintenance is quite low for high-quality components and tested designs

Suitable cranes:

- [FB42L](#)
- [FB47L](#)
- [FB51L](#)
- [FB53T](#)
- [FB63T](#)
- [FB63TS](#)

Technical characteristics

Trailer with standard equipment

<i>Parameter</i>	<i>FB50D</i>	<i>Parameter</i>	<i>FB50D</i>
Permitted weight*, kg	7 000	Wheels	400/60–15.5
Loading capacity, kg	5 000	Hydr. drawbar steering	–
Load area, m ²	1,4	Hydr. support legs	Telescopic
Weight*, kg	1250	Bunks	4
Load length, m	3,7	Stakes	8
Frame, mm	140x180		

* Weights may vary depending on the equipment and brakes

Technical drawings

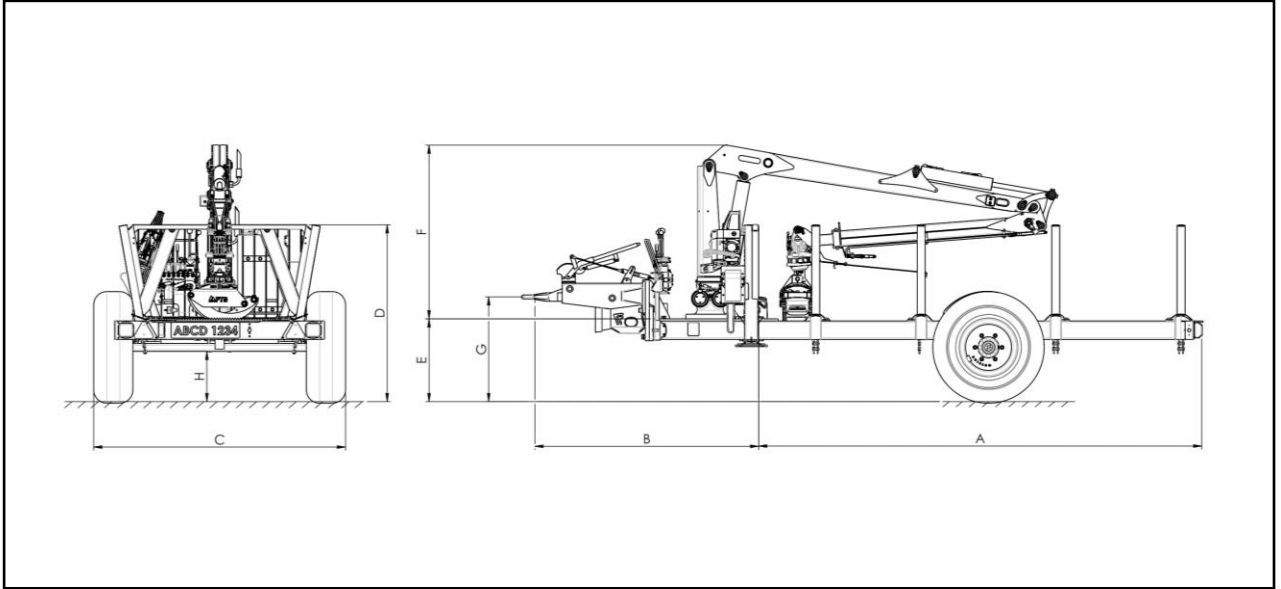















Trailer	Crane	Wheels	A	B	C	D	E	F	G	H
FB50D	FB42L	400/60-15.5	3660	1885	2100	1665	1100	1230	625-825	400
	FB47L		3660	1885	2100	1665	1100	1330	625-825	400
	FB51L		3660	1885	2100	1665	1100	1390	625-825	400
	FB53T		3660	1885	2100	1665	1100	1330	625-825	400
	FB63T (S)		3660	1885	2100	1665	1100	1360	625-825	400

* Dimensions may vary depending on the equipment



FB50D accessories

Independent hydraulic system		Toolbox with cover		Grapple holder	
Operators platform with ladder		Operators platform with seat		Block valve for telescopic support legs	
Parking leg		Parking wheel		Insert plates	
Shoes for telescopic support legs		Fuel tank holder with tank		Wheel support set	
Plywood floor lining		Wheels 480/45-17 Road profile		Wheels 480/45-17 Traction profile	

Brake options

- Hydraulic brakes
- Air brakes

Drawbar options

- Upwards drawbar



FTG BALTIC UAB

Dūmų st. 3 K20
LT-11119 Vilnius, Lithuania
+370 5 246 23 18
sales.vilnius@ftgforest.com

For more information: www.ftgkallefall.com

By combining our Swedish heritage with constant innovation based on the needs of customers, we design forest trailers and cranes that impress by their consistently pleasant performance.

FTG Källefall forest trailers can pass through challenging terrains and are robustly built to withstand tough conditions in the forest. Trailers' capacity varies from 3 to 12 tones. Our trailers can be supplemented with telescopic cranes, ranging from 4,2 to 9,4 meters reach. Källefall cranes are strong, fast, and easy to operate. We also offer a wide range of timber grapples and other accessories to meet different needs.